

# Company Profile of ThreeBond Co., Ltd.

Industrial sealant and adhesive manufacturer

Creating Our Future From a Single Drop



|                                |   |
|--------------------------------|---|
| <b>Corporate name :</b>        | ThreeBond Co., Ltd.   |
| <b>Date of establishment :</b> | May 1955  |
| <b>Representative :</b>        | Makoto Kinoshita, President   |
| <b>Capital :</b>               | 300 million yen   |
| <b>Sales :</b>                 | ThreeBond Group : 76.5 billion yen (fiscal 2017) ~590 M€  |
| <b>Number of employees :</b>   | Full-time employees of ThreeBond Co., Ltd.: 401<br>Employees of the ThreeBond Group: 2,870 (as of the end of Dec. 2017) |
| <b>Headquarters :</b>          | 1456 Hazama-cho, Hachioji-shi, Tokyo  |



## To contribute to the “production” around the world, with the cutting-edge technologies for sealing agents and adhesives

We have developed networks across 6 regions: Japan, North/Central Americas, South America, Europe, Asia, and China.

We develop products mainly in the 4 sectors: “Transportation Equipment,” “Electrical and Electronics,” “Industrial Materials and Public Works,” and “Automotive Aftermarket.”

The teamwork in each section of “Sales,” “R&D,” “Production,” and “Quality Assurance” supports our cutting-edge technologies.



**ThreeBond Europe SAS**



**ThreeBond Singapore Pte Ltd.**



**ThreeBond Manufacturing (Thailand) Co., Ltd.**



**ThreeBond Technology (Thailand) Co., Ltd.**

**Shanghai Songjiang ThreeBond Chemicals Co., Ltd.**



**ThreeBond Chemical Industry Shanghai Co., Ltd.**



**ThreeBond Co., Ltd.**



**ThreeBond Hong Kong Co., Ltd.**



**ThreeBond International, inc. (Moraine Plant)**



**ThreeBond International, Inc.**



**ThreeBond Do Brasil ind. E Comercio Ltda.**



## Transportation Equipment

### Epoch-making “liquid gasket” created by the founder



- Main products
  - Liquid gaskets
  - Silicone-based liquid gaskets and potting agents
  - Strong anaerobic sealants
  - Agents for preventing screw loosening, leakage and rust and more...

## Industrial Materials and Public Works

### Provision of sealing agents produced mainly from special polymer materials



- Main products
  - Sealants for general, service water and gas piping
  - Caulking compounds
  - Construction-use silicone sealants
  - Agents for preventing screw loosening, leakage and rust and more...

## Electrical and Electronics

### For the cutting-edge production of compact, thin, and highly-functional products



- Main products
  - Ultraviolet curing resins
  - Electrically conductive resins
  - Pickup-use damper materials
  - Heat dissipating agents
  - Electrical-use silicone adhesives
  - Epoxy compound resin and more...

## Automotive Aftermarket

### Provision of a variety of products for beautifying and maintaining automobiles



- Main products
  - Chassis coating agents
  - Brake & parts cleaners
  - Glass-type body coating
  - Rust-proof lubricants
  - Silicone-based liquid gaskets and potting agents and more...

## Sales

**Sales activities are essential to the existence of business. Prioritizing customers is the basis of our sales activities.**



The sales section of ThreeBond is a group of sales specialists. Our sales activities are conducted face-to-face with customers while proposing ideas.

## R&D

**We aim to conduct research and development while foreseeing the needs of users.**



We develop comprehensive systems including technologies for blending and processing liquid materials for new products and production technologies in various industrial fields.

## Production

**We meet various needs with our global production and supply networks.**



We have 2 production sites in Japan and 7 outside Japan. We strive to improve our services and quality while considering customer needs around the world.

## Quality Assurance

**We promote measures for improving both quality and environmental safety.**



We have developed an original management system that satisfies ISO9001 and ISO14001.

Cutting-edge R&D and information transmission  
are the core of our global strategy.



■ Top-level devices and research/analysis equipment among sealing agent and adhesive manufacturers



■ Trace element analyzer



■ Dynamic mechanical analyzer



■ Tensile tester



■ Thermostat inspection chamber



■ Environmental test laboratory

## ThreeBond Group sales progress

Unit: 1 million yen

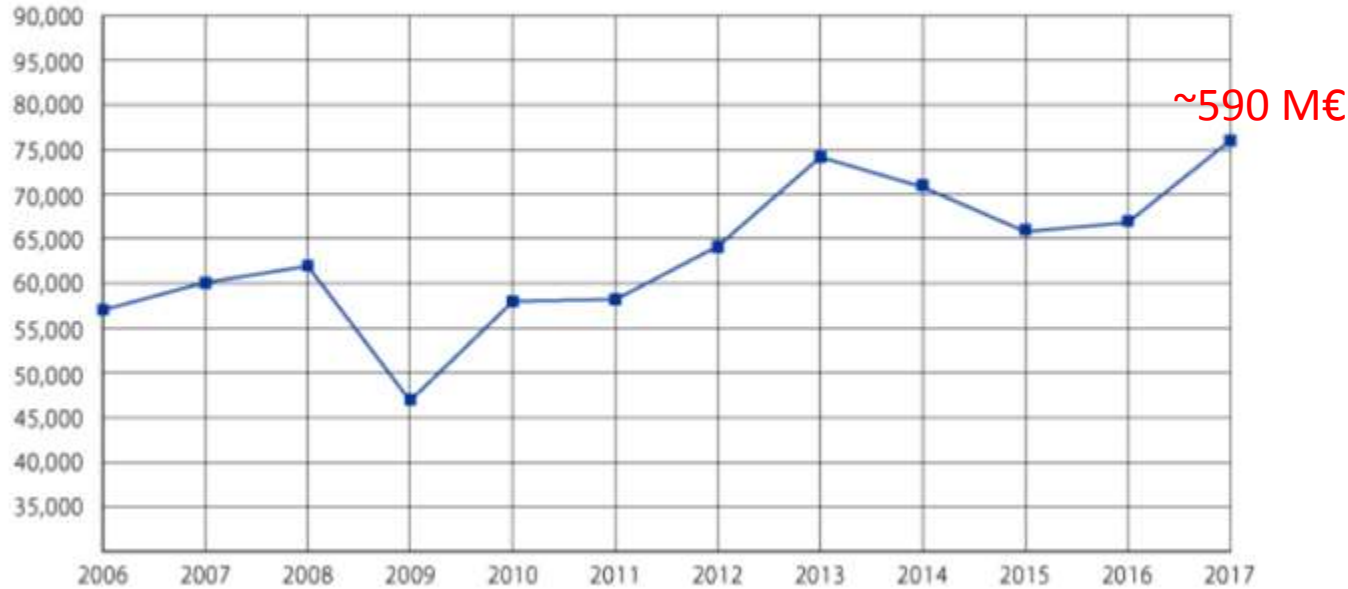

The results of overseas companies are converted into yen using the average exchange rate at that period of time.

More than 60% are sales outside Japan

## Sales by Market Categories (2017)

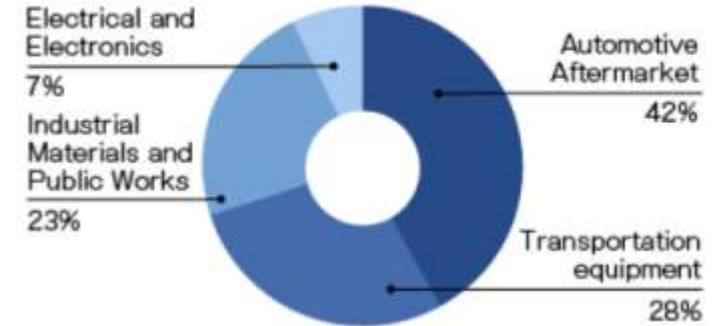

## Sales results of each product (2017)

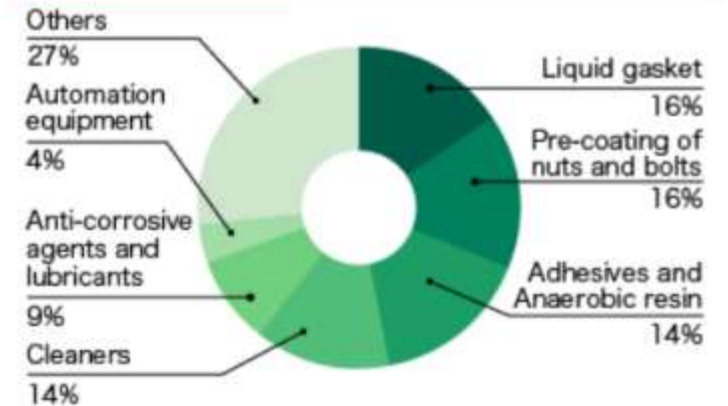



## Liquid Gaskets



These are liquid sealants used for sealing inner fluids by applying them to the joint surfaces of various flanges, screws, etc., in transportation equipment and industrial equipment.

Highly reliable sealing is achieved by filling in and adhering to the minute clearance on the joint surface.

Also, they are a liquid when applied, so metal joint surfaces touch each other, and there is almost no decrease in surface pressure due to vibration, etc. Therefore, they are durable and have excellent sealability.

Products with various material bases are available including synthetic resin-based, synthetic rubber-based, acrylate-based, acrylic emulsion-based, and silicone-based.

There are also various reaction system grades including solvent vaporization, anaerobic curing, and moisture-curing.

Products include general-purpose types, and products for FIPG and CIPG.



## Anaerobic Adhesives and Sealants



These are single-component type acrylic anaerobic adhesives and sealants. In addition to bonding and sealing of screws and interlocking parts, they can also be used for magnet surface adhesion, and bonding and sealing of metal materials. When air (oxygen) supply is cut between metal materials such as when a screw is tightened and the gaps of the threads are minimized, curing reaction begins due to the metal ions, and curing by polymerization occurs rapidly.

For screws, after around 20 seconds to a few minutes, it cures to where it cannot be moved (set time), and from 30 minutes to 2 hours it reaches 1/2 of final strength (practical strength). After 12 to 24 hours, it reaches final strength, and it forms a tough cured material with excellent oil resistance, chemical resistance, heat resistance, and weather resistance.

It can be used in a temperature range from -40°C to 150°C (approx.) (200°C for heat-resistant type).

There are also types with UV curability and primer curability in addition to anaerobic curing property.

A halogen-free type is also available.



## Agents for Preventing Screw Loosening, Leaks and Rust



These are single-component type solvent vaporizing-type screw-fixing agents. They can be used for bonding small screws, mainly size M6 and smaller. They have penetrability, so they can be applied after tightening. After application, it penetrates to the threaded portion, and the solvent vaporizes, resulting in the formation of a resin-based cured material that can prevent loosening and leakage. These are also good for preventing rust at threaded portions. It is possible to loosen by a force that is about 10 to 20% higher than the tightening torque, so they can be removed easily when necessary. For M6 size screws, 1/2 of the final strength (practical strength) is achieved after one or two days, and it reaches final strength after three days. It can be used in a temperature range from below -40°C to 80°C (approx.).



## Threelock and Sealock Processes to Prevent Leaks and Loosening of Screws



This is the process for coating the sealant and locking agent to the thread portion of screws, bolts, pipes, etc. to add sealing and locking functions to screws themselves. Pre-coated screws maintain stability, and have sealing or locking functions when tightened. Pre-coating of bolts includes bolts pre-coated by MEC Processing where a microencapsulated reactive adhesive is applied, Threelock Processing where nylon is fused, and Sealock Processing where a sealing function is added.



## Elastomeric Adhesives



These are single-component type solventless moisture-curing adhesives. The curing reaction occurs from the moisture in the air when it is squeezed from the container, and it becomes a rubber-like elastic body. They have excellent adhesive strength for a wide range of materials including metals, plastics, rubber, wood, and inorganic materials. After curing, they have elasticity so they provide excellent bonding between different types of materials due to the high peel strength. The 1530 Series begins to have a strong initial tackiness in just 5 to 10 minutes after application, and temporary adhesion is possible without a jig. Depending on the bonding area, it can reach 1/2 of the final strength (practical strength) after 12 to 24 hours, and it reaches final strength after 3 to 7 days. The 1532 Series reaches practical strength after two days, and reaches final strength after three to seven days, becoming a cured material with high elongation. There is also a low-viscosity type and a type with incombustibility (certified according to incombustibility standards). 1533 is compliant with REACH.



## Instant Adhesives Gold Label Instant Adhesives



These are single-component type instant adhesives that use cyanoacrylate as the main component. When bonding, the adhesives cure in several seconds due to the trace of moisture that exists on the adhesion surface, and bonding occurs within a few seconds to a few minutes. They are single component products, so they are easy to use and have excellent adhesion strength in a short time for a wide range of materials including metals, plastics, rubber, wood, and inorganic materials. There is a gel type, a low-odor / low-blooming type, an ultra-rapid curing type, a high peel-strength type, a highly moisture- and heat-resistant type, and a light-curing type.



## Epoxy Resins



These are adhesives that use epoxy resin as the main component. They have strong adhesion strength and have excellent overall characteristics including chemical resistance, electrical properties, and mechanical strength. There is a two-component type that cures at room temperature, and a single-component type that is a heat-curing type. They can be used for various purposes including general-purpose adhesion and sealing, for construction materials, and for electronic device bonding, filling, repair, casting, and impregnation.



## UV Curing Resins



These are single-component solventless type adhesives with curing in several seconds by UV light irradiation. They have excellent adhesion to various materials such as metals, plastics, and glass, and are used for many purposes including bonding, sealing, casting, and coating of electric and electronic devices, automobile parts, optical parts, and accessories, etc. There are many variations available including acrylate-based, epoxy-based, and silicone-based products, and there are grades with different curability including visible-light-curing, anaerobic curing, heat-curing, moisture-curing, and primer curing in addition to curing under UV light. Therefore, it is possible to cure portions that do not receive UV light and to bond materials that do not transmit UV light. There are many grades available according to physical properties including a type that forms a tough cured material with high hardness and a type that forms a flexible cured material with rubber elasticity.



## Electrically Conductive Resins · Anisotropically Conductive Pastes

Electrical and Electronics

These are conductive adhesives that have conductive materials that consist of electro conductive fillers evenly dispersed in the synthetic resin that work as an adhesive/binder.

By applying and curing at bonding locations requiring conductivity, they show excellent adhesion and conductivity.

Silver, nickel, carbon, etc., are used as electro conductive fillers, and epoxy resin, urethane resin, silicone resin, synthetic rubber, etc., which have good physical properties, are used as binders. There are various grades available.

They have excellent adhesion with various materials including metals, plastics, glass, and rubber, and can be used for bonding lead wires and electrodes, and for semiconductor elements and EMI shield parts.

In addition, anisotropically-conductive adhesives for screen printing can be used for multiple-contact simultaneous connection of displays such as LCDs.



## Heat Dissipating Agents

Transportation Equipment

Electrical and Electronics

Industrial Materials and Public Works

This is a series of one-part moisture-curing resins for heat dissipation that use a silyl-containing special polymer as the base resin and contain a thermally conductive filler.

They are in a liquid state, so they have excellent adhesion and filling property resulting in good heat dissipation.

In addition, they are reaction type products, so there is no increase of flowability or separation over time. All grades do not contain low molecular weight cyclic siloxane, which can cause electrical contact failure, so they can be used for insulation and heat dissipation with various electronic parts including switching power supplies, power ICs, and computer CPUs.



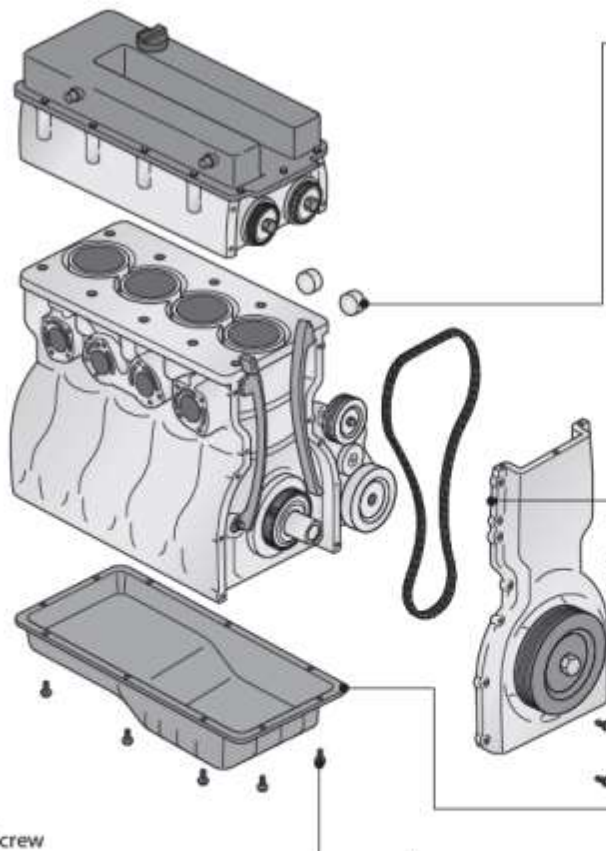

### Welch Plug

|                 |  |
|-----------------|--|
| Application     | Fitting, Fixing, Sealing   |
| Product         | ThreeBond 1380 Series  |
| Characteristics | <ol style="list-style-type: none"> <li>1. Good durability</li> <li>2. Grades with low to high strength available</li> <li>3. Florescence, axial force added types available</li> </ol> |
| Curing method   | Moisture curing  |

### Oil Pan/ Chain case/ Oil pump

|                 |  |
|-----------------|--|
| Application     | Flange sealing   |
| Product         | ThreeBond 1217 Series  |
| Characteristics | <ol style="list-style-type: none"> <li>1. De-oxide type</li> <li>2. Good engine oil resistance</li> <li>3. Good initial pressure resistance</li> <li>4. Good resistance to heat, cold and oil</li> <li>5. Good flexibility, high elongation grades available</li> <li>6. Good oil surface adhesion grade available</li> <li>7. Good Magnesium material adhesion grade available</li> </ol> |
| Curing method   | Moisture curing  |

### Bolt, Screw

|                 |  |
|-----------------|--|
| Application     | Fixing, Sealing  |
| Product         | ThreeBond 2400 Series  |
| Characteristics | <ol style="list-style-type: none"> <li>1. Fix by simply tightening</li> <li>2. Good durability</li> <li>3. Grades with low to high strength available</li> <li>4. Acrylic- and epoxy-based products available</li> </ol> |

## Powertrain

## Transmission

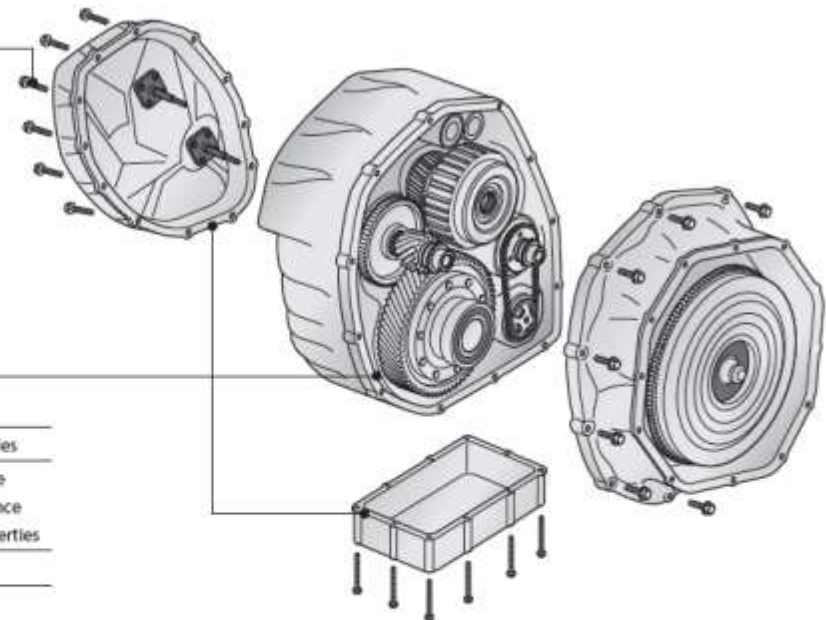

### Transmission case / Oil pan

|                 |   |
|-----------------|---|
| Application     | Flange sealing  |
| Product         | ThreeBond 1216 Series   |
| Characteristics | <ol style="list-style-type: none"> <li>1. Good oil resistance</li> <li>2. Good heat resistance</li> <li>3. Good sealing properties</li> </ol> |
| Curing method   | Moisture curing   |

## Electronic Control Unit (ECU)

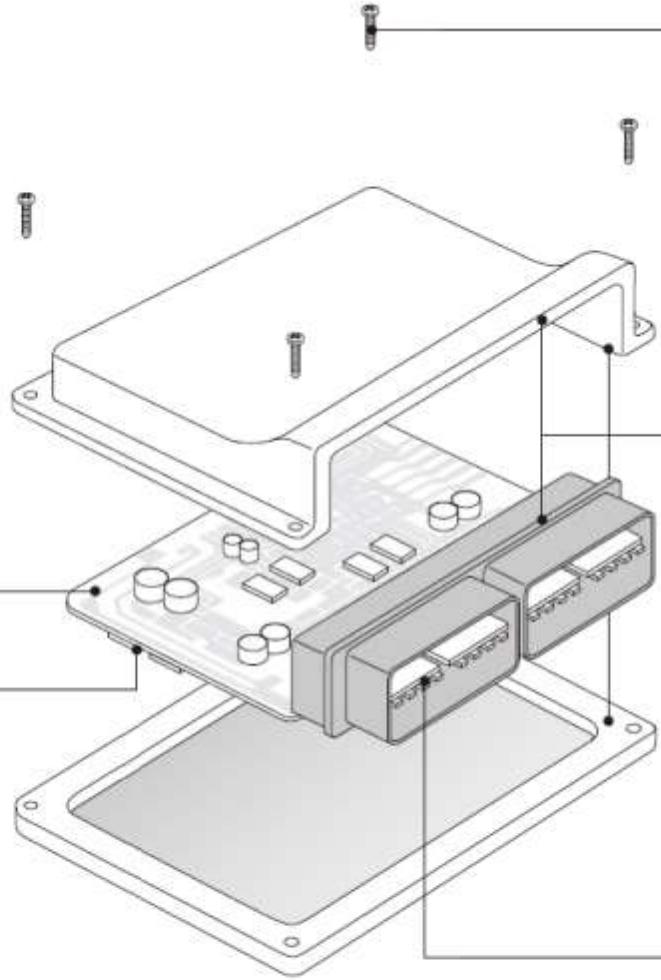

### Substrate

|                 |   |
|-----------------|---|
| Application     | Protective coating  |
| Product         | ThreeBond 1100 Series<br>ThreeBond 3075 Series<br>ThreeBond 3160 Series |
| Characteristics | 1. Corrosion prevention<br>2. Migration prevention<br>3. Good adhesion  |
| Curing method   | Solvent volatilization, UV curing                                       |

### Substrate element

|                 |   |
|-----------------|---|
| Application     | Heat radiation  |
| Product         | ThreeBond 12258<br>ThreeBond 2955 Series  |
| Characteristics | 1. Good heat radiation<br>2. Good electrical properties<br>3. Low-molecular cyclic siloxane-reduced product |
| Curing method   | Moisture-curing   |
| Application     | Heat radiation  |
| Product         | ThreeBond 2270 Series   |
| Characteristics | 1. Good heat radiation<br>2. Good electrical properties<br>3. Good adhesion                                 |
| Curing method   | Heat-curing   |

### Case

|                 |  |
|-----------------|--|
| Application     | Sealing and bonding (FIPG)   |
| Product         | ThreeBond 1226   |
| Characteristics | 1. Tin-free<br>2. Good adhesion<br>3. Low-molecular cyclic siloxane-reduced product      |
| Curing method   | Moisture-curing  |
| Application     | Sealing and bonding (FIPG)   |
| Product         | ThreeBond 12348  |
| Characteristics | 1. Good durability<br>2. Good adhesion<br>3. Good followability                          |
| Curing method   | Heat-curing  |
| Application     | Sealing (CIGP)   |
| Product         | ThreeBond 3081J  |
| Characteristics | 1. Good durability<br>2. Low-compression permanent deformation<br>3. Reworking available |
| Curing method   | UV curing  |

### Screw

|                 |   |
|-----------------|---|
| Application     | Fixing  |
| Product         | ThreeBond 2400 Series   |
| Characteristics | 1. Only tightening generates strength of adhesion.<br>2. Good durability<br>3. Grades with low to high strength available<br>4. Acrylic- and epoxy-based products available |

### Connector

|                 |   |
|-----------------|---|
| Application     | Sealing   |
| Product         | ThreeBond 3160 Series   |
| Characteristics | 1. Good durability<br>2. Good adhesion<br>3. Low-molecular cyclic siloxane-reduced product      |
| Curing method   | UV curing (with moisture curing added)  |
| Application     | Sealing   |
| Product         | ThreeBond 2200 Series   |
| Characteristics | 1. Good durability<br>2. Grades that cure fast at low temperature available<br>3. Good adhesion |
| Curing method   | Heat-curing   |

**Inverter – Converter - Charger**

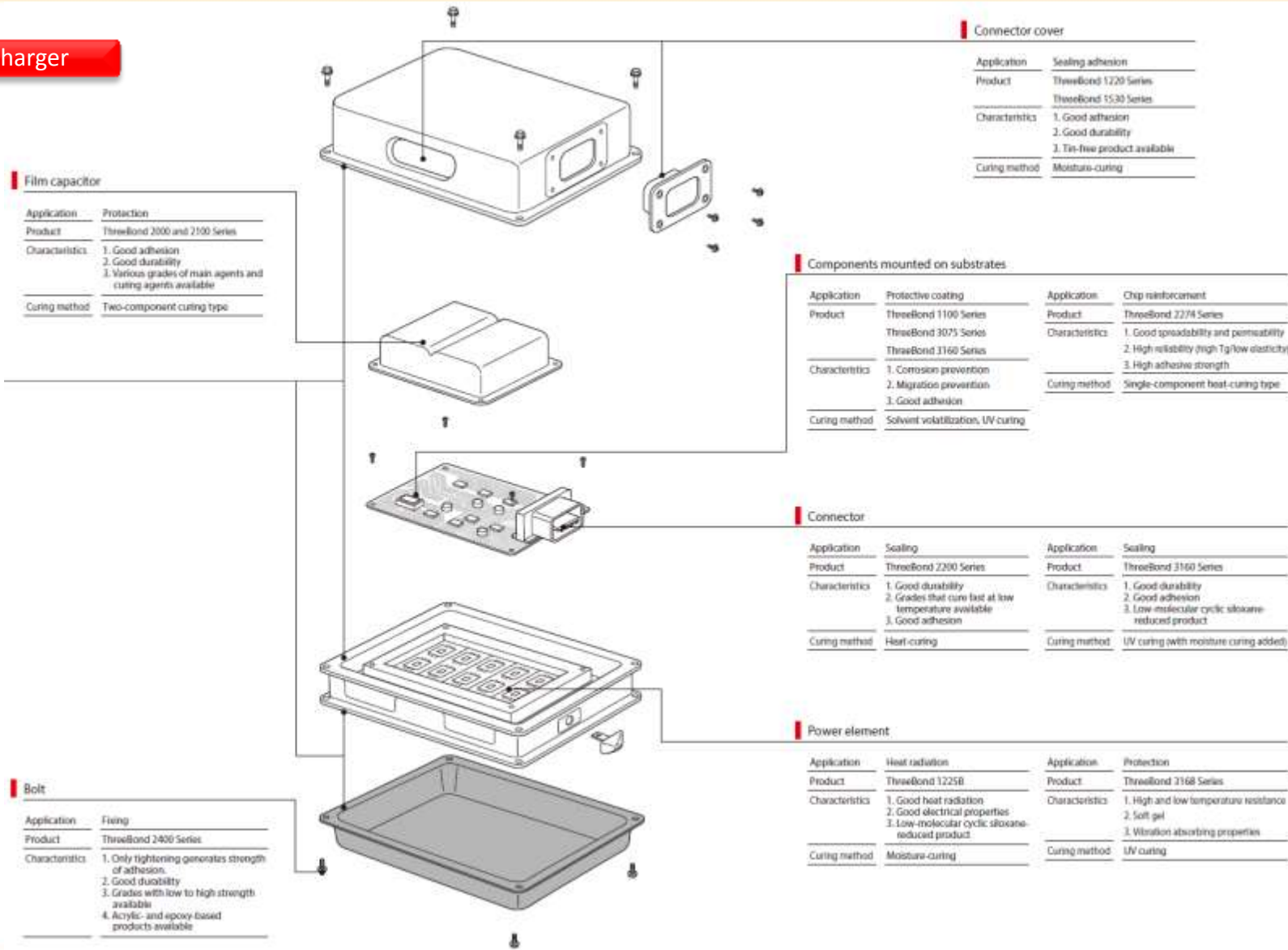

**Film capacitor**

|                 |  |
|-----------------|--|
| Application     | Protection   |
| Product         | ThreeBond 2000 and 2100 Series   |
| Characteristics | 1. Good adhesion<br>2. Good durability<br>3. Various grades of main agents and curing agents available |
| Curing method   | Two-component curing type  |

**Bolt**

|                 |   |
|-----------------|---|
| Application     | Fixing  |
| Product         | ThreeBond 2400 Series   |
| Characteristics | 1. Only tightening generates strength of adhesion.<br>2. Good durability<br>3. Grades with low to high strength available<br>4. Acrylic- and epoxy-based products available |

**Connector cover**

|                 |   |
|-----------------|---|
| Application     | Sealing adhesion  |
| Product         | ThreeBond 1220 Series<br>ThreeBond 1530 Series                          |
| Characteristics | 1. Good adhesion<br>2. Good durability<br>3. Tin-free product available |
| Curing method   | Moisture-curing   |

**Components mounted on substrates**

|                 |   |                 |   |
|-----------------|---|-----------------|---|
| Application     | Protective coating  | Application     | Chip reinforcement  |
| Product         | ThreeBond 1100 Series<br>ThreeBond 3075 Series<br>ThreeBond 3160 Series | Product         | ThreeBond 2274 Series   |
| Characteristics | 1. Corrosion prevention<br>2. Migration prevention<br>3. Good adhesion  | Characteristics | 1. Good spreadability and permeability<br>2. High reliability (high Tg/low elasticity)<br>3. High adhesive strength |
| Curing method   | Solvent volatilization, UV curing                                       | Curing method   | Single-component heat-curing type   |

**Connector**

|                 |   |
|-----------------|---|
| Application     | Sealing   |
| Product         | ThreeBond 2200 Series   |
| Characteristics | 1. Good durability<br>2. Grades that cure fast at low temperature available<br>3. Good adhesion |
| Curing method   | Heat-curing   |

|                 |  |
|-----------------|--|
| Application     | Sealing  |
| Product         | ThreeBond 3160 Series  |
| Characteristics | 1. Good durability<br>2. Good adhesion<br>3. Low-molecular cyclic siloxane-reduced product |
| Curing method   | UV curing (with moisture curing additive)  |

**Power element**

|                 |   |                 |  |
|-----------------|---|-----------------|--|
| Application     | Heat radiation  | Application     | Protection   |
| Product         | ThreeBond 1225B   | Product         | ThreeBond 216B Series  |
| Characteristics | 1. Good heat radiation<br>2. Good electrical properties<br>3. Low-molecular cyclic siloxane-reduced product | Characteristics | 1. High and low temperature resistance<br>2. Soft gel<br>3. Vibration absorbing properties |
| Curing method   | Moisture-curing   | Curing method   | UV curing  |



## Reactor coil

|                 |   |
|-----------------|---|
| Application     | Heat radiation  |
| Product         | ThreeBond 1225B   |
| Characteristics | 1. Good heat radiation<br>2. Good electrical properties<br>3. Low-molecular cyclic siloxane-reduced product |
| Curing method   | Moisture-curing   |

|                 |   |
|-----------------|---|
| Application     | Heat radiation  |
| Product         | ThreeBond 2270 Series   |
| Characteristics | 1. Good adhesion<br>2. Good durability<br>3. Grades with higher heat resistance available |
| Curing method   | Heat-curing   |

## Capacitor

|                 |  |
|-----------------|--|
| Application     | Sealing  |
| Product         | ThreeBond 2222P  |
| Characteristics | 1. Good solder heat resistance<br>2. Good durability<br>3. Good adhesion |
| Curing method   | Heat-curing  |

## Components mounted on substrates

|                 |  |
|-----------------|--|
| Application     | Fixing   |
| Product         | ThreeBond 1537 Series<br>ThreeBond 2272F   |
| Characteristics | 1. Product certified by V-0 in the flame resistance standard UL94<br>2. Low cure shrinkage<br>3. Good adhesion |
| Curing method   | Normal-temperature curing, heat curing   |

## Inverter – Converter

## Mini Motor

### Winding coil

|                 |   |
|-----------------|---|
| Application     | Fixing / Impregnating   |
| Product         | ThreeBond 2240 Series<br>ThreeBond 2280 Series  |
| Characteristics | 1. Good heat resistance (High Tg)<br>2. Good chemical resistance<br>3. Good electrical properties |
| Curing method   | Heat-curing   |

### Magnet

|                 |   |
|-----------------|---|
| Application     | Bonding   |
| Product         | ThreeBond 3955 Series   |
| Characteristics | 1. Fast curing at normal temperature<br>2. High heat and moisture resistance<br>3. Good flexibility |
| Curing method   | Two-component normal temperature curing   |

|                 |   |
|-----------------|---|
| Product         | ThreeBond 1350 Series<br>ThreeBond 1360 Series                        |
| Characteristics | 1. High heat resistance<br>2. High adhesiveness<br>3. Good curability |
| Curing method   | Anaerobic curing  |

|                 |   |
|-----------------|---|
| Product         | ThreeBond 2240 Series<br>ThreeBond 2280 Series  |
| Characteristics | 1. Good heat resistance<br>2. Good chemical resistance<br>3. Good electrical properties |
| Curing method   | Heat-curing   |

### Blanket

|                 |   |
|-----------------|---|
| Application     | Bonding   |
| Product         | ThreeBond 2222P   |
| Characteristics | 1. Good heat resistance<br>2. Good adhesion<br>3. Good durability |
| Curing method   | Heat-curing   |

### Case

|                 |   |
|-----------------|---|
| Application     | Bonding (FPG)   |
| Product         | ThreeBond 1226  |
| Characteristics | 1. Tin free<br>2. Good adhesion<br>3. Low molecular cyclic siloxane-reduced product |
| Curing method   | Moisture curing   |

|                 |   |
|-----------------|---|
| Product         | ThreeBond 3950 Series                   |
| Characteristics | 1. Good flexibility<br>2. Good adhesion |
| Curing method   | Two-component normal temperature curing |

### Shaft and bearings

|                 |   |
|-----------------|---|
| Application     | Fitting   |
| Product         | ThreeBond 1350 Series<br>ThreeBond 1360 Series                        |
| Characteristics | 1. High heat resistance<br>2. High adhesiveness<br>3. Good curability |
| Curing method   | Anaerobic curing  |

### Connector cable

|                 |   |
|-----------------|---|
| Application     | Bonding   |
| Product         | ThreeBond 1539  |
| Characteristics | 1. Fast curing at low temperature<br>2. Good adhesion<br>3. Good durability |
| Curing method   | Heat-curing   |

|                 |  |
|-----------------|--|
| Product         | ThreeBond 1533F  |
| Characteristics | 1. Good adhesion to hardly adherable materials<br>2. Dipolyim compounds free product<br>3. Low molecular cyclic siloxane-reduced product |
| Curing method   | Moisture curing  |

### Screw

|                 |   |
|-----------------|---|
| Application     | Fixing  |
| Product         | ThreeBond 2400 Series   |
| Characteristics | 1. Strength of adhesion generated by simply tightening<br>2. Good durability<br>3. Grades with low to high strength available<br>4. Acrylic- and epoxy-based products available |

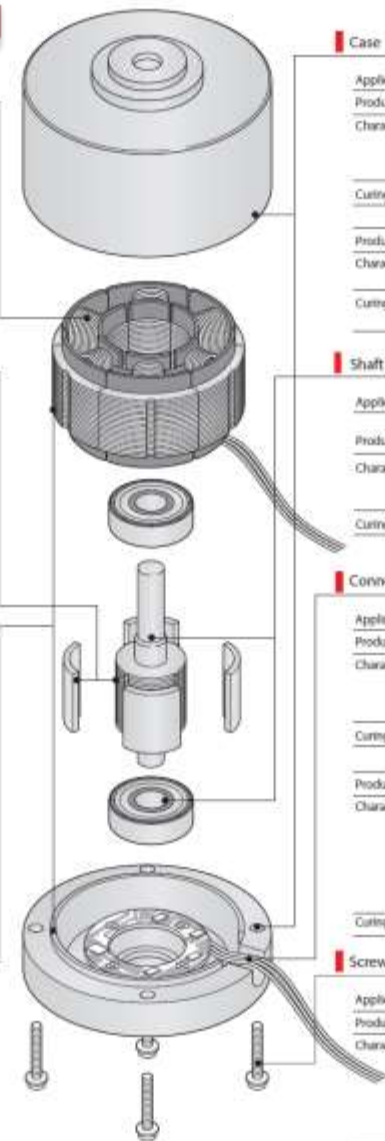

## Drive Motor

### Motor case

|                 |   |
|-----------------|---|
| Application     | Flange sealing  |
| Product         | ThreeBond 1216 Series   |
| Characteristics | 1. High oil resistance<br>2. High heat resistance<br>3. Good sealing property |
| Curing method   | Moisture-curing   |

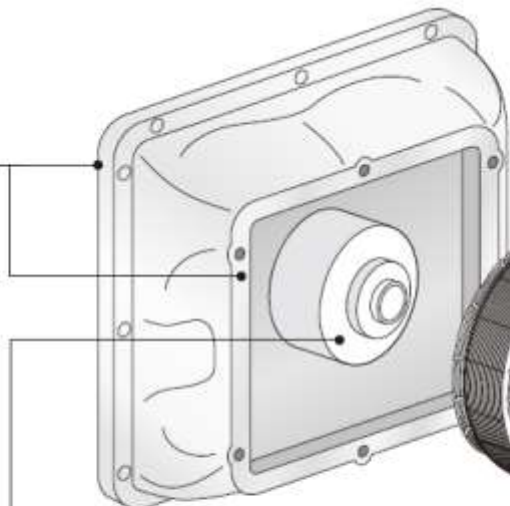

### Rotor



|                 |  |
|-----------------|--|
| Application     | Magnet fixing  |
| Product         | ThreeBond 2240 Series<br>ThreeBond 2280 Series                               |
| Characteristics | 1. High heat resistance<br>2. Good adhesion<br>3. Good electrical properties |
| Curing method   | Heat-curing  |

### Stator

|                 |   |
|-----------------|---|
| Application     | Protection (winding wire section)   |
| Product         | ThreeBond 2280 Series   |
| Characteristics | 1. High heat resistance<br>2. Good chemical resistance<br>3. Good electrical properties |
| Curing method   | Heat-curing   |

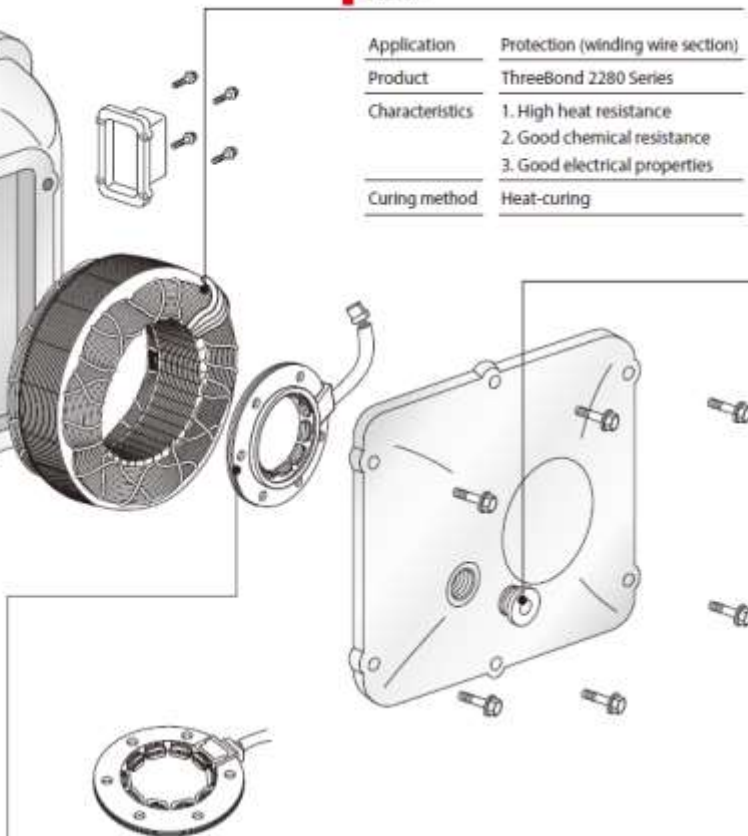

### Angle sensor (resolver)

|                 |  |                 |   |
|-----------------|--|-----------------|---|
| Application     | Protection (terminal and winding wire section)                           | Application     | Protection (terminal and winding wire section)  |
| Product         | ThreeBond 1156 Series  | Product         | ThreeBond 1220 Series   |
| Characteristics | 1. Good flexibility<br>2. High heat resistance<br>3. High oil resistance | Characteristics | 1. Dealcoholization type<br>2. High heat resistance<br>3. Products for flame resistance and electric contacts available |
| Curing method   | Heat-curing  | Curing method   | Moisture-curing   |

### Plug

|                 |   |
|-----------------|---|
| Application     | Fixing and sealing  |
| Product         | ThreeBond 1380 Series   |
| Characteristics | 1. Good durability<br>2. Grades with low to high strength available<br>3. Type with fluorescence and axial force added available  |
| Curing method   | Anaerobic curing  |
| Application     | Fixing  |
| Product         | ThreeBond 2400 Series   |
| Characteristics | 1. Only tightening generates strength of adhesion.<br>2. Good durability<br>3. Grades with low to high strength available<br>4. Acrylic- and epoxy-based products available |

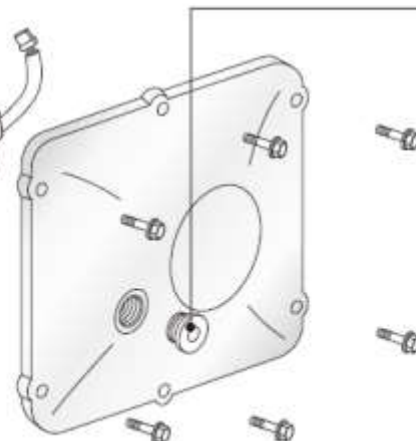

## Keyless remote control

### IC Chip

|                 |   |
|-----------------|---|
| Application     | Temporary chip fixing   |
| Product         | ThreeBond 3177  |
| Characteristics | <ol style="list-style-type: none"> <li>1. Curable with low integrated light quantity</li> <li>2. Good adhesion of each adherend material</li> <li>3. Good durability</li> </ol> |
| Curing method   | Light curing<br>Moisture curing   |

|                 |  |
|-----------------|--|
| Application     | Chip reinforcement   |
| Product         | ThreeBond 2274 Series  |
| Characteristics | <ol style="list-style-type: none"> <li>1. Good coating properties and permeability</li> <li>2. High reliability (High Tg/ low elasticity)</li> <li>3. High adhesiveness</li> </ol> |
| Curing method   | Heat-curing  |

### Keypad film

|                 |  |
|-----------------|--|
| Application     | Temporary film fixing  |
| Product         | ThreeBond 7700 Series  |
| Characteristics | <ol style="list-style-type: none"> <li>1. Fast curable</li> <li>2. Good adhesion</li> <li>3. Good durability</li> <li>4. Gel, high peeling, impact resistant type</li> </ol> |
| Curing method   | Moisture curing  |

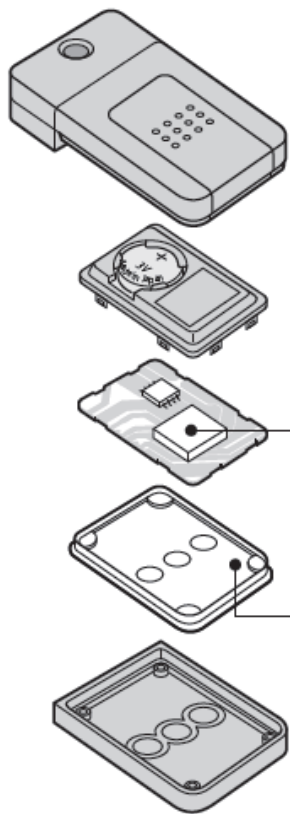

## Around the body

### Weather strip

|                 |   |
|-----------------|---|
| Application     | Protection, Fixing  |
| Product         | ThreeBond 1530 Series   |
| Characteristics | <ol style="list-style-type: none"> <li>1. Good adhesion</li> <li>2. Good durability</li> <li>3. Tin-free compatible products available</li> </ol> |
| Curing method   | Moisture curing   |

### Door visor spoiler

|                 |  |
|-----------------|--|
| Application     | Bonding, Sealing   |
| Product         | PANDO 690 Series   |
| Characteristics | <ol style="list-style-type: none"> <li>1. Good adhesion</li> <li>2. Good durability</li> </ol> |

### Touch sensor

|                 |  |
|-----------------|--|
| Application     | Bonding, Sealing, Protecting   |
| Product         | ThreeBond 3000 Series<br>ThreeBond 1537 Series<br>ThreeBond 1539 Series  |
| Characteristics | <ol style="list-style-type: none"> <li>1. Good durability</li> <li>2. Good adhesion and sealing</li> <li>3. Hardly adhesive material compatible grade available</li> </ol> |
| Curing method   | UV curing<br>Moisture curable  |

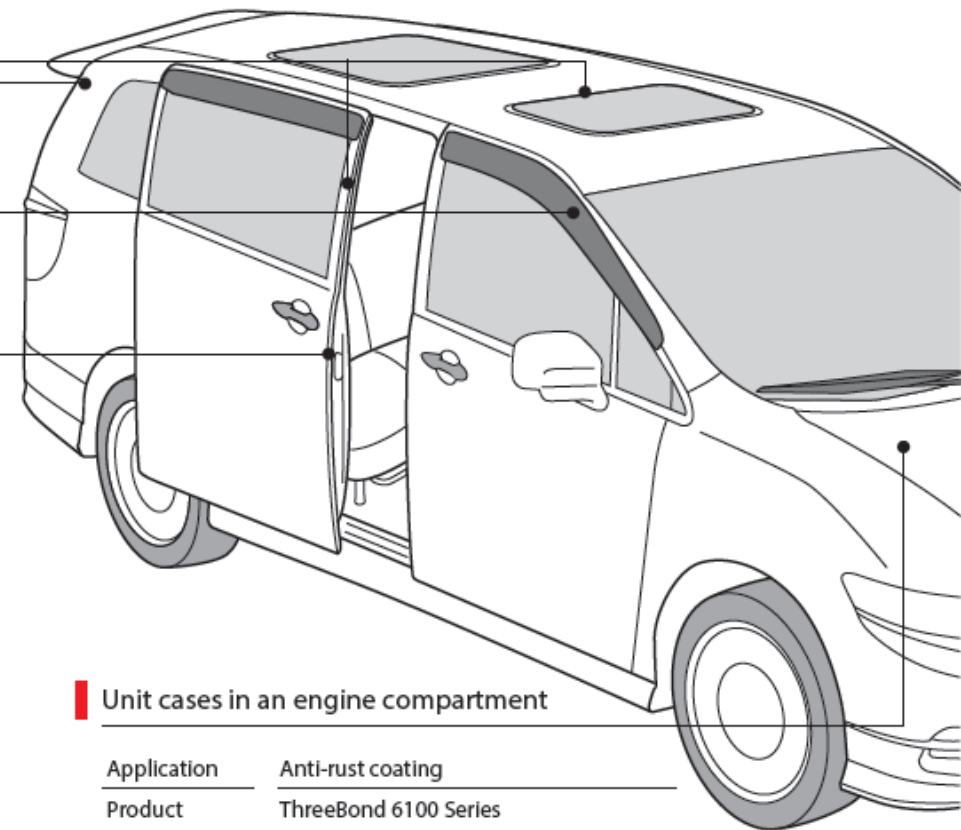

### Unit cases in an engine compartment

|                 |  |
|-----------------|--|
| Application     | Anti-rust coating  |
| Product         | ThreeBond 6100 Series  |
| Characteristics | <ol style="list-style-type: none"> <li>1. Good anti-rust properties</li> <li>2. Good durability</li> <li>3. Water type available (Product non-compatible with organic solvent poisoning prevention regulations)</li> </ol> |
| Curing method   | Normal temperature curing  |

## Mirror

### Mirror

|                 |  |
|-----------------|--|
| Application     | Bonding                                |
| Product         | PANDO 690 Series                       |
| Characteristics | 1. Good adhesion<br>2. Good durability |

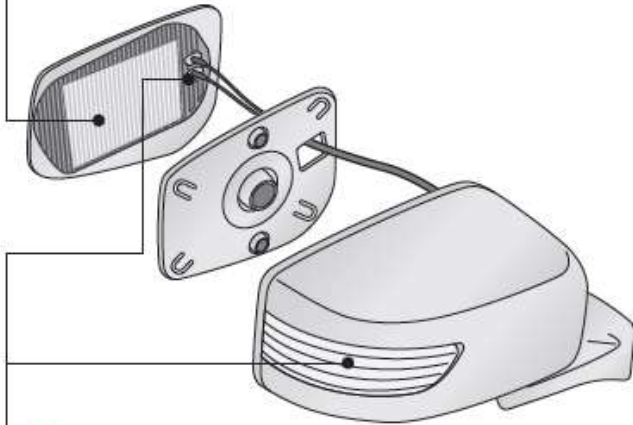

### Terminal, side turn signal cable

|                 |   |
|-----------------|---|
| Application     | Protection, Fixing, Sealing   |
| Product         | ThreeBond 1530 Series   |
| Characteristics | 1. Good adhesion<br>2. Good durability<br>3. Tin free compatible products available |
| Curing method   | Moisture curing   |

## Corner sensor

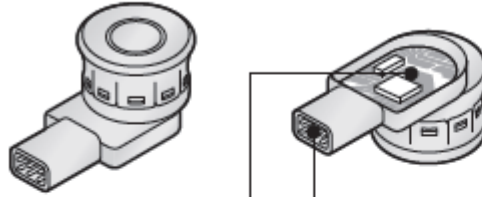

### Board-mounted components

|                 |  |
|-----------------|--|
| Application     | Protecting, Sealing  |
| Product         | ThreeBond 3160 Series<br>ThreeBond 1537 Series<br>ThreeBond 1539 Series  |
| Characteristics | 1. Good durability<br>2. Good adhesion and sealing properties<br>3. Vibration absorbency (soft gel products available) |
| Curing method   | UV curing (moisture curing type available)<br>Moisture curing  |

## Keyless entry button

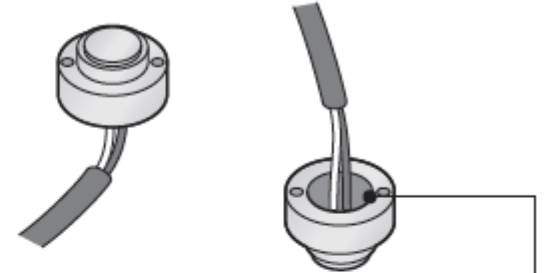

### Connector, terminal

|                 |  |
|-----------------|--|
| Application     | Sealing  |
| Product         | ThreeBond 2200 Series  |
| Characteristics | 1. Good durability<br>2. Low temperature rapid curable grade available<br>3. Good adhesion |
| Curing method   | Heat-curing  |

## Headlight

### Light source element

|                 |   |
|-----------------|---|
| Application     | Heat radiation  |
| Product         | ThreeBond 1225 Series   |
| Characteristics | 1. Good heat radiation<br>2. Good electrical properties<br>3. Low molecular cyclic siloxane-reduced product |
| Curing method   | Moisture curing   |

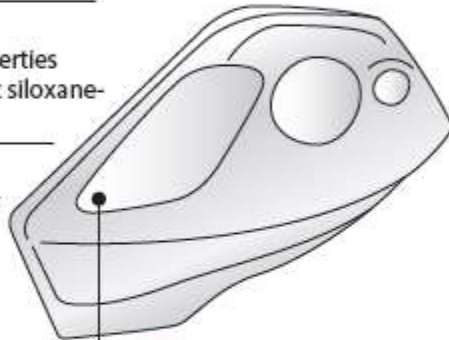

### Screw

|                 |   |
|-----------------|---|
| Application     | Fixing, Sealing   |
| Product         | ThreeBond 2400 Series   |
| Characteristics | 1. Only tightening generates strength of adhesion<br>2. Good durability |

### Light source control unit

|                 |   |
|-----------------|---|
| Application     | Sealing, Bonding  |
| Product         | ThreeBond 1226  |
| Characteristics | 1. Tin free<br>2. Good adhesion<br>3. Low molecular cyclic siloxane reduced product |
| Curing method   | Moisture curing   |

### Terminal



|                 |  |
|-----------------|--|
| Application     | Sealing  |
| Product         | ThreeBond 2200 Series  |
| Characteristics | 1. Good durability<br>2. Low temperature rapid curable grade available<br>3. Good adhesion |
| Curing method   | Heat-curing  |



|                 |  |
|-----------------|--|
| Application     | Sealing  |
| Product         | ThreeBond 3160 Series  |
| Characteristics | 1. Good durability<br>2. Good adhesion<br>3. Low molecular cyclic siloxane reduced product |
| Curing method   | UV curing (with moisture curing added)   |

## Battery

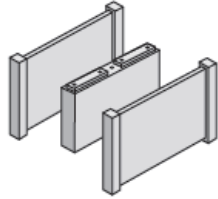

### Lithium ion secondary battery square cell

|                 |   |
|-----------------|---|
| Application     | Liquid electrolyte sealing  |
| Product         | ThreeBond 1152 Series<br>ThreeBond 1171 Series  |
| Characteristics | 1. Good resistance to liquid electrolyte<br>2. Low moisture permeability<br>3. Grades that cure fast at low temperature available |
| Curing method   | Heat curing, solvent volatilization   |
| Application     | Cell heat radiation   |
| Product         | ThreeBond 1225 Series   |
| Characteristics | 1. Good heat radiation<br>2. Good electrical properties<br>3. Low-molecular cyclic siloxane-reduced product                       |
| Curing method   | Moisture-curing   |

### Stack

|                 |   |
|-----------------|---|
| Application     | Cell fixing   |
| Product         | ThreeBond 3955 Series   |
| Characteristics | 1. Fast curing at normal temperature<br>2. High heat and moisture resistance<br>3. Good flexibility |
| Curing method   | Two-component normal-temperature curing   |

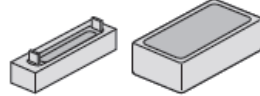

### Electrical components and sensors

|                 |  |
|-----------------|--|
| Application     | Sealing  |
| Product         | ThreeBond 3160 Series  |
| Characteristics | 1. Good durability<br>2. Good adhesion<br>3. Low-molecular cyclic siloxane-reduced product |
| Curing method   | UV curing (with moisture curing added)   |

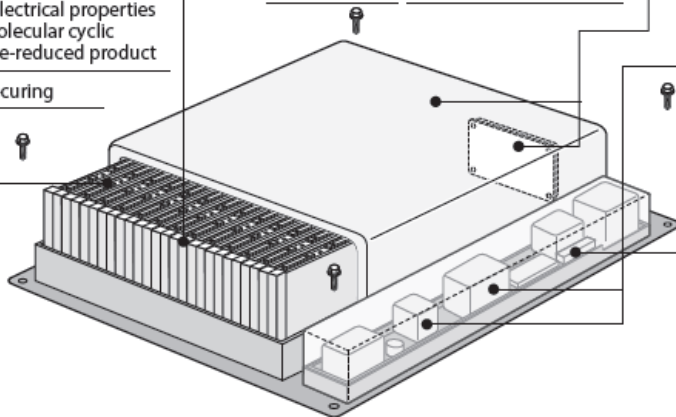

### Unit case

|                 |   |
|-----------------|---|
| Application     | Sealing adhesion  |
| Product         | ThreeBond 1226  |
| Characteristics | 1. Tin-free<br>2. Good adhesion<br>3. Low-molecular cyclic siloxane-reduced product |
| Curing method   | Moisture-curing   |

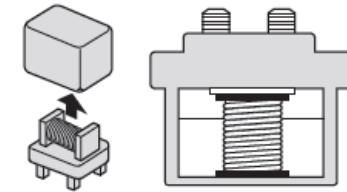
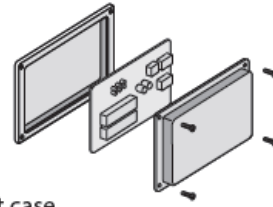

### Relay

|                 |   |
|-----------------|---|
| Application     | Relay sealant   |
| Product         | ThreeBond 2200 Series   |
| Characteristics | 1. Grades for solder reflow available<br>2. Good durability<br>3. Good adhesion |
| Curing method   | Heat-curing   |

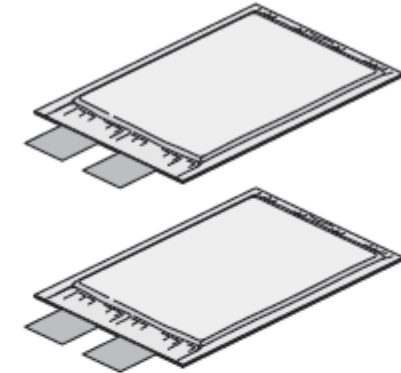

### Lithium ion secondary battery laminated type cell

|                 |   |
|-----------------|---|
| Application     | Cell lamination adhesion  |
| Product         | ThreeBond 1533F   |
| Characteristics | 1. Good adhesion to hardly ad-herable materials<br>*Primer treatment unnecessary since it is single-component<br>2. Dibutyltin compounds-free product<br>3. Low molecular cyclic siloxane-reduced product |
| Curing method   | Moisture curing   |

## Li Ion Secondary Battery

|                 |  |
|-----------------|--|
| Application     | Liquid electrolyte sealing   |
| Product         | ThreeBond 1171 Series  |
| Characteristics | 1. Resistance to liquid electrolyte (PC, EC, etc.)<br>2. Low moisture permeability |
| Cure condition  | Solvent-vaporizing type  |

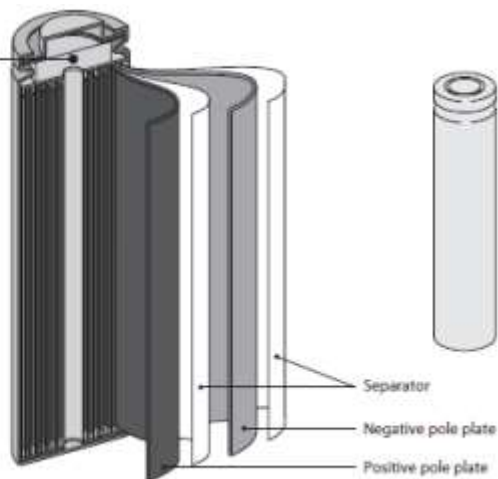

## Li Ion Secondary Battery

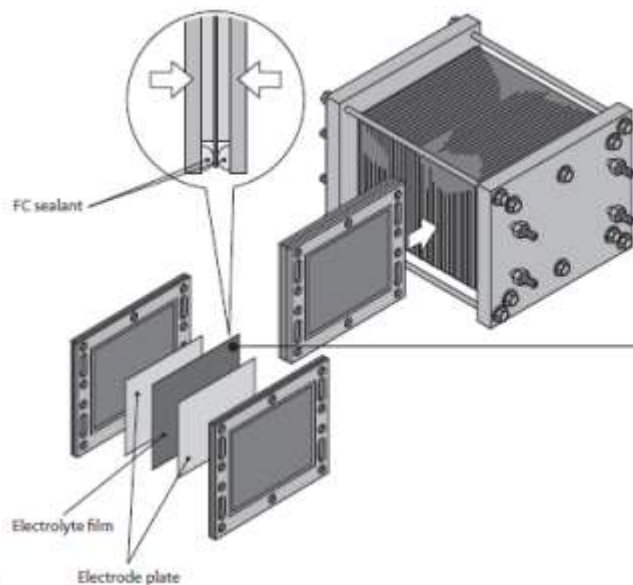

## Fuel Cell Battery

### Fuel Battery Seal

|                 |   |
|-----------------|---|
| Application     | Gas sealing   |
| Product         | ThreeBond 1152 Series<br>ThreeBond 1153 Series            |
| Characteristics | 1. Chemical resistance (acid, alkaline)<br>2. Flexibility |
| Cure condition  | Single-component heat curing                              |

## Alkaline Battery

### Alkaline Battery

|                 |   |
|-----------------|---|
| Application     | Liquid electrolyte sealing  |
| Product         | ThreeBond 1170 Series<br>ThreeBond 1184 Series                            |
| Characteristics | 1. Resistance to liquid electrolyte (KOH)<br>2. Low moisture permeability |
| Cure condition  | Solvent-vaporizing type   |

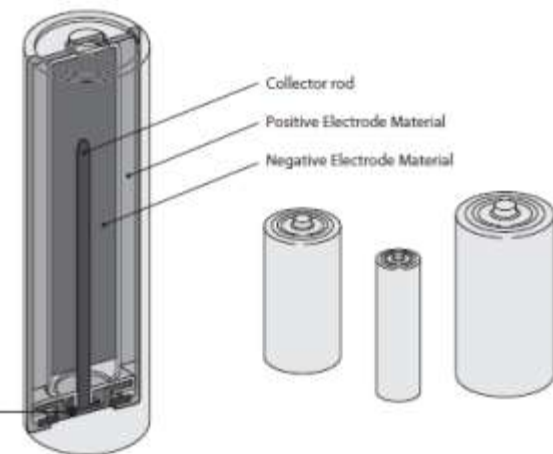

## Dye Sensitized Solar Battery

|                 |   |
|-----------------|---|
| Application     | Liquid electrolyte sealing  |
| Product         | ThreeBond 3035 Series<br>ThreeBond 3118   |
| Characteristics | 1. Resistance to liquid electrolyte (acetonitrile, GBL, PC, 3-MPN, etc.)<br>2. Low moisture permeability<br>3. High reliability |
| Cure condition  | UV curing / UV curing + Heat curing   |

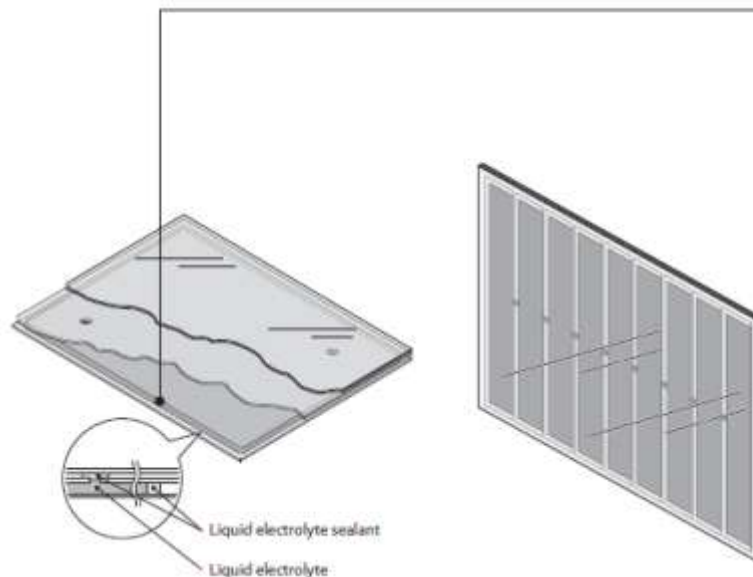

## Dye Sensitized Solar Cell (DSSC)

## Car Mounted Camera

**Lens fitting portion**

|                 |   |
|-----------------|---|
| Application     | Casing sealing and bonding  |
| Product         | ThreeBond 2202 Series<br>ThreeBond 2296 Series  |
| Characteristics | 1. Fast curing at low temperature<br>2. Good adhesion to each adherend material<br>3. Good durability |
| Curing method   | Heat-curing   |

**Case**

|                 |   |
|-----------------|---|
| Application     | Case sealing  |
| Product         | ThreeBond 3081 Series   |
| Characteristics | 1. Good durability<br>2. Low compression permanent deformation<br>3. Reworking possible |
| Curing method   | UV curing   |

**Adjustment screw and barrel**

|                 |   |
|-----------------|---|
| Application     | Screw fixing  |
| Product         | ThreeBond 2296 Series   |
| Characteristics | 1. Fast curing at low temperature<br>2. Good adhesion to each adherend material<br>3. Good durability |
| Curing method   | Heat-curing   |

**Optical lens**

|                 |  |
|-----------------|--|
| Application     | Lens fixing  |
| Product         | ThreeBond 3114 Series<br>ThreeBond 3038 Series   |
| Characteristics | 1. Low cure shrinkage<br>2. Good adhesion to each adherend material<br>3. LED curing available (3038 Series) |
| Curing method   | UV curing  |

**Lens holder**

|                 |   |
|-----------------|---|
| Application     | Bonding   |
| Product         | ThreeBond 3164 Series<br>ThreeBond 2296 Series<br>ThreeBond 3114 Series                               |
| Characteristics | 1. Fast curing at low temperature<br>2. Good adhesion to each adherend material<br>3. Good durability |
| Curing method   | UV curing (with moisture curing added)<br>Heat-curing, UV curing                                      |

**IR cut filter**

|                 |   |
|-----------------|---|
| Application     | Bonding, Fixing   |
| Product         | ThreeBond 3170 Series<br>ThreeBond 2296 Series  |
| Characteristics | 1. Good adhesion to each adherend material<br>2. Good durability<br>3. Visible light curing available (3170 Series) |
| Curing method   | UV curing (Visible light possible),<br>heat curing  |

**IC chip**

|                 |   |
|-----------------|---|
| Application     | Chip reinforcement  |
| Product         | ThreeBond 2274 Series   |
| Characteristics | 1. Good coating properties and permeability<br>2. High reliability (high Tg/low elasticity)<br>3. High adhesiveness |
| Curing method   | Heat-curing   |

**Substrate**

|                 |   |
|-----------------|---|
| Application     | Substrate bonding   |
| Product         | ThreeBond 3114 Series<br>ThreeBond 3038 Series  |
| Characteristics | 1. Low cure shrinkage<br>2. Good adhesion to each adherend material<br>3. LED curing possible (3038 Series) |
| Curing method   | UV curing   |

**Connector**

|                 |  |
|-----------------|--|
| Application     | Connector bonding, Sealing   |
| Product         | ThreeBond 3164 Series<br>ThreeBond 1537 Series<br>ThreeBond 1539                                       |
| Characteristics | 1. Good durability<br>2. Good adhesion and sealing<br>3. Low molecular cyclic siloxane-reduced product |
| Curing method   | UV curing (with moisture curing added)<br>Moisture curable   |

## Wire Harness

**Connector**

|                 |  |
|-----------------|--|
| Application     | Sealing  |
| Product         | ThreeBond 3013Q<br>ThreeBond 1156 Series                                 |
| Characteristics | 1. Good flexibility<br>2. High heat resistance<br>3. High oil resistance |
| Curing method   | UV curing/heat curing  |

**Terminal**

|                 |   |
|-----------------|---|
| Application     | Protection  |
| Product         | ThreeBond 3000 Series   |
| Characteristics | 1. Good adhesion<br>2. Grades with flexibility available<br>3. Grades with moisture and heat curing added available |
| Curing method   | UV curing   |

**Terminal**

|                 |  |
|-----------------|--|
| Application     | Protection   |
| Product         | ThreeBond 3160 Series  |
| Characteristics | 1. Good adhesion<br>2. Good adhesion<br>3. Low molecular cyclic siloxane-reduced product |
| Curing method   | UV curing (with moisture curing added)   |



## OLED Displays



### Organic EL display Hollow sealant

|                 |   |
|-----------------|---|
| Application     | Seal  |
| Product         | ThreeBond 3124 series   |
| Characteristics | 1. Low moisture permeability<br>2. High reliability (High Tg, Low modulus)<br>3. Visible light cure |
| Cure condition  | UV curing + Heat curing   |

### Organic EL display Fixing sealant

|                 |  |
|-----------------|--|
| Application     | Seal   |
| Product         | ThreeBond 1655 series  |
| Characteristics | 1. High transparency<br>2. Flexibility<br>3. Even film thickness |
| Cure condition  | Heat curing  |

### Structure of hollow sealant

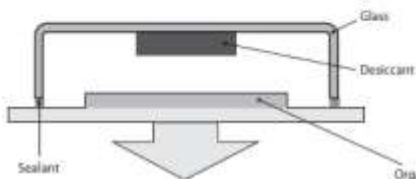

### Structure of sealing of solid substance

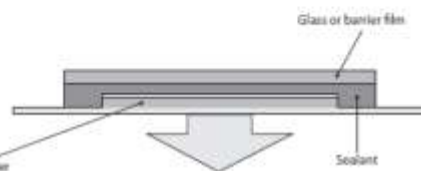

### Liquid crystal display

|                 |   |
|-----------------|---|
| Application     | Liquid crystal panel end face coating   |
| Product         | ThreeBond 3020B   |
| Characteristics | 1. High strength of adhesion to glass and resin<br>2. Blackening after UV irradiation<br>3. Deep curability |
| Cure condition  | UV curing / LED curing  |

### Liquid crystal display parts area

|                 |  |
|-----------------|--|
| Application     | Fixing parts   |
| Product         | ThreeBond 1533 series<br>ThreeBond 1538 series                   |
| Characteristics | 1. Possible curing at 25°C<br>2. Adhesion to different materials |
| Cure condition  | Moisture curing  |

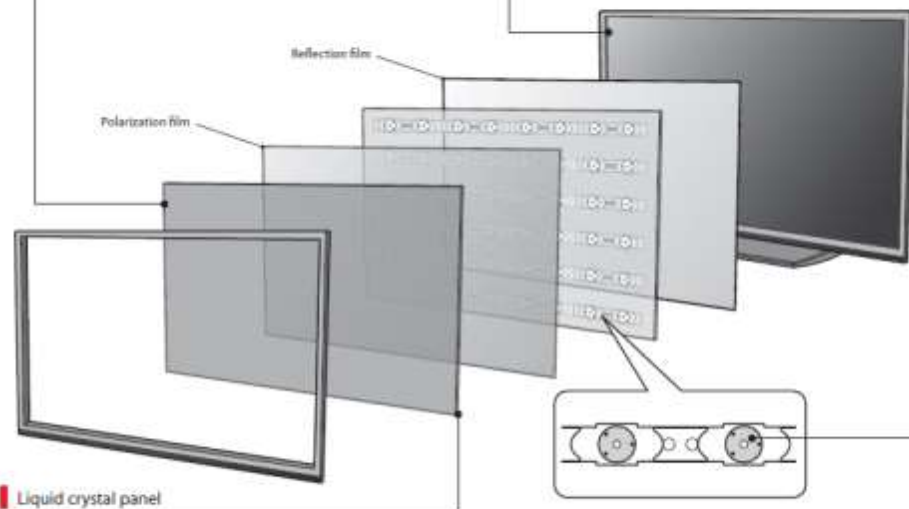

### Liquid crystal panel

|                 |  |
|-----------------|--|
| Application     | Connection reinforcement   |
| Product         | ThreeBond 3027G<br>ThreeBond 3074C   |
| Characteristics | 1. High releasability<br>2. Adhesion different materials<br>3. Fast curability |
| Cure condition  | UV curing  |

|                 |   |
|-----------------|---|
| Application     | Grounding   |
| Product         | ThreeBond 3315F<br>ThreeBond 3331D<br>ThreeBond 3350C                                 |
| Characteristics | 1. Curing at 80°C for 60 min<br>2. Low resistivity<br>3. High adhesion to metal parts |
| Cure condition  | Heat curing   |

### Back Light Module

|                 |   |
|-----------------|---|
| Application     | Fixing diffusing lens   |
| Product         | ThreeBond 2206S<br>ThreeBond 2296B<br>ThreeBond 3074C                                       |
| Characteristics | 1. Curing at 60 to 80°C for 30 min<br>2. Adhesion different materials<br>3. Fast curability |
| Cure condition  | Heat curing / UV curing   |

## LCD Displays

## Smartphone

**Legend:**

- Cover glass
- ThreeBond 1633
- Touch panel module
- ThreeBond 1633
- Liquid crystal panel module

**Touch panel module/Liquid crystal panel module**

|  |  |
|--|--|
| <b>Application:</b> Adhesive of a cover glass/touch panel module to a liquid crystal panel module                    | <b>Application:</b> Connection of touch panel terminals  |
| <b>Product:</b> ThreeBond 1631 (30 to 200 µm)  | <b>Product:</b> ThreeBond 3371 (0.5/100/100)<br>ThreeBond 3375 Series (0.5/200/200)  |
| <b>Characteristics:</b> 1. Uniform film thickness<br>2. Flexibility<br>3. High transparency                          | <b>Characteristics:</b> 1. Suitability for screen printing<br>2. Stability after printing and drying<br>3. Compression bonding at low temperature possible (120°C x 3MPa x 10 sec) |
| <b>Cure condition:</b> UV curing   | <b>Cure condition:</b> Drying by heating (film formation) and thermocompression bonding  |
| <b>Application:</b> FPC reinforcement  | <b>Application:</b> Grounding  |
| <b>Product:</b> ThreeBond 3017 Series<br>ThreeBond 3027 Series   | <b>Product:</b> ThreeBond 3313F<br>ThreeBond 3315H   |
| <b>Characteristics:</b> 1. Flexibility<br>2. High ductility<br>3. Bonding of a different type of material to another | <b>Characteristics:</b> 1. Fast-curing property<br>2. Flexibility  |
| <b>Cure condition:</b> UV curing   | <b>Cure condition:</b> Heat curing   |

**Crystal device**

|  |
|--|
| <b>Application:</b> Crystal piece connection and fixing  |
| <b>Product:</b> ThreeBond 3303 Series  |
| <b>Characteristics:</b> 1. Good reliability when heated<br>2. Minute amount application possible |
| <b>Cure condition:</b> Heat curing   |

**Vibrating motor**

|  |
|--|
| <b>Application:</b> Magnet fixing  |
| <b>Product:</b> ThreeBond 3358/1390 Series<br>ThreeBond 2296 Series<br>ThreeBond 3060 Series |
| <b>Characteristics:</b> 1. Fast-curing property<br>2. Shadow-zone curability                 |
| <b>Cure condition:</b> Anaerobic curing, heat curing, and UV curing                          |

**Case**

|  |
|--|
| <b>Application:</b> Prevention of small screws from loosening                            |
| <b>Product:</b> ThreeBond 2365 Series (screw-processing product)                         |
| <b>Characteristics:</b> 1. Prevention of loosening and dropping<br>2. Good repeatability |

**Cover panel**

|  |
|--|
| <b>Application:</b> Cover panel circumference adhesion   |
| <b>Product:</b> ThreeBond 3359 Series  |
| <b>Characteristics:</b> 1. Reaction starts in one minute at about 60°C<br>2. A plant based material is used<br>3. Elasticity is generated in a wide temperature range (-35 to 100°C) |
| <b>Cure condition:</b> Heat curing   |

**Camera module**

|  |  |
|--|--|
| <b>Application:</b> Lens fixing  | <b>Application:</b> Folder fixing  |
| <b>Product:</b> ThreeBond 3030 Series  | <b>Product:</b> ThreeBond 2206 Series<br>ThreeBond 3140 Series   |
| <b>Characteristics:</b> 1. High strength of adhesion to resin lenses<br>2. High strength of adhesion to resin materials<br>3. Fast-curing property | <b>Characteristics:</b> 1. Fast-curing property<br>2. High strength of adhesion to resin materials<br>3. High thixotropic properties |
| <b>Cure condition:</b> UV curing   | <b>Cure condition:</b> Heat curing/UV and heat curing  |
| <b>Application:</b> IR cut-off filter fixing   | <b>Application:</b> Lens case fixing   |
| <b>Product:</b> ThreeBond 2296 Series<br>ThreeBond 3170 Series   | <b>Product:</b> ThreeBond 2296 Series  |
| <b>Characteristics:</b> 1. Fast-curing property<br>2. Deep curability<br>3. High strength of adhesion to resin materials                           | <b>Characteristics:</b> 1. Fast-curing property<br>2. High strength of adhesion to resin materials<br>3. High thixotropic properties |
| <b>Cure condition:</b> Heat curing/visible light and UV curing   | <b>Cure condition:</b> Heat curing   |

**Capacitor**

|  |
|--|
| <b>Application:</b> Connection without using solder            |
| <b>Product:</b> ThreeBond 3350 Series                          |
| <b>Characteristics:</b> 1. Flexibility<br>2. Impact resistance |
| <b>Cure condition:</b> Heat curing                             |

**Inductor**

|  |
|--|
| <b>Application:</b> Prevention of winding wires from being frayed            |
| <b>Product:</b> ThreeBond 2296 Series<br>ThreeBond 3060 Series               |
| <b>Characteristics:</b> 1. Fast-curing property<br>2. Shadow zone curability |
| <b>Cure condition:</b> Heat curing, anaerobic curing and UV curing           |

**BGA and CSP**

|   |
|---|
| <b>Application:</b> BGA and CSP reinforcement   |
| <b>Product:</b> ThreeBond 2274 Series   |
| <b>Characteristics:</b> 1. Good spreadability and permeability<br>2. High reliability (high Tg and low elasticity)<br>3. High adhesion strength |
| <b>Cure condition:</b> Heat curing  |

## Smartwatch

### Touch sensor / Display panel

|                 |   |
|-----------------|---|
| Application     | Sticking Cover panel / Touch sensor / Display panel                 |
| Product         | ThreeBond 1631  |
| Characteristics | 1. Uniform film thickness<br>2. Flexibility<br>3. High transparency |
| Cure condition  | UV curing   |

|                 |  |
|-----------------|--|
| Application     | Display gap filling  |
| Product         | ThreeBond 1535 Series<br>ThreeBond 1539  |
| Characteristics | 1. Bonding of a different type of material to another<br>2. Elasticity is generated in a wide temperature range (-35 to 100°C) |
| Cure condition  | Moisture curing / Heat curing  |

|                 |   |
|-----------------|---|
| Application     | FPC reinforcement   |
| Product         | ThreeBond 3027G<br>ThreeBond 3074C  |
| Characteristics | 1. High detachability<br>2. Bonding of a different type of material to another<br>3. Fast-curing property |
| Cure condition  | UV curing   |

|                 |   |
|-----------------|---|
| Application     | Grounding                                     |
| Product         | ThreeBond 3331D<br>ThreeBond 3350C            |
| Characteristics | 1. Fast-curing property<br>2. Low resistivity |
| Cure condition  | Heat curing                                   |



### Li ion secondary battery

|                 |  |
|-----------------|--|
| Application     | Fixing   |
| Product         | ThreeBond 1535 Series  |
| Characteristics | 1. Bonding of a different type of material to another<br>2. Elasticity is generated in a wide temperature range (-35 to 100°C) |
| Cure condition  | Moisture curing  |

### Substrate

|                 |   |
|-----------------|---|
| Application     | Waterproof coating  |
| Product         | ThreeBond 1535 Series<br>ThreeBond 3074C                              |
| Characteristics | 1. Adhesion - Sealability<br>2. Durability<br>3. Unheated Heat-curing |
| Cure condition  | Moisture curing / UV curing   |

### Cover panel

|                 |   |
|-----------------|---|
| Application     | Cover panel end face coating  |
| Product         | ThreeBond 3020B   |
| Characteristics | 1. High strength of adhesion to glass and resin<br>2. Blackening after UV irradiation<br>3. Deep curability |
| Cure condition  | UV curing / LED curing  |

|                 |  |
|-----------------|--|
| Application     | Cover panel circumference adhesion   |
| Product         | ThreeBond 1535 Series<br>ThreeBond 3074C                                       |
| Characteristics | 1. High strength of adhesion to glass and metal<br>2. High sealing performance |
| Cure condition  | Moisture curing / UV curing  |

### Vibrating motor

|                 |   |
|-----------------|---|
| Application     | Magnet fixing   |
| Product         | ThreeBond 1357K/1390B<br>ThreeBond 22065<br>ThreeBond 3062U |
| Characteristics | 1. Fast-curing property<br>2. Shadow-zone curability        |
| Cure condition  | Anaerobic curing (UV curing) / heat curing                  |

|                 |  |
|-----------------|--|
| Application     | Coil and FPC fixing  |
| Product         | ThreeBond 22065<br>ThreeBond 3065E   |
| Characteristics | 1. Fast-curing property<br>2. Bonding of a different type of material to another |
| Cure condition  | Heat curing / UV curing (Anaerobic curing)                                       |

### IC

|                 |  |
|-----------------|--|
| Application     | K heat dissipation   |
| Product         | ThreeBond 1225 Series  |
| Characteristics | 1. High thermal conductivity (1.59 to 2.5W/m·K)<br>2. Low molecular weight cyclic siloxane reduced product |
| Cure condition  | Moisture curing  |

### Case

|                 |   |
|-----------------|---|
| Application     | Waterproof CPG  |
| Product         | ThreeBond 3081 Series   |
| Characteristics | 1. Low compression permanent distortion<br>2. Flexibility<br>3. High sealing performance<br>4. Flowable |
| Cure condition  | UV curing   |

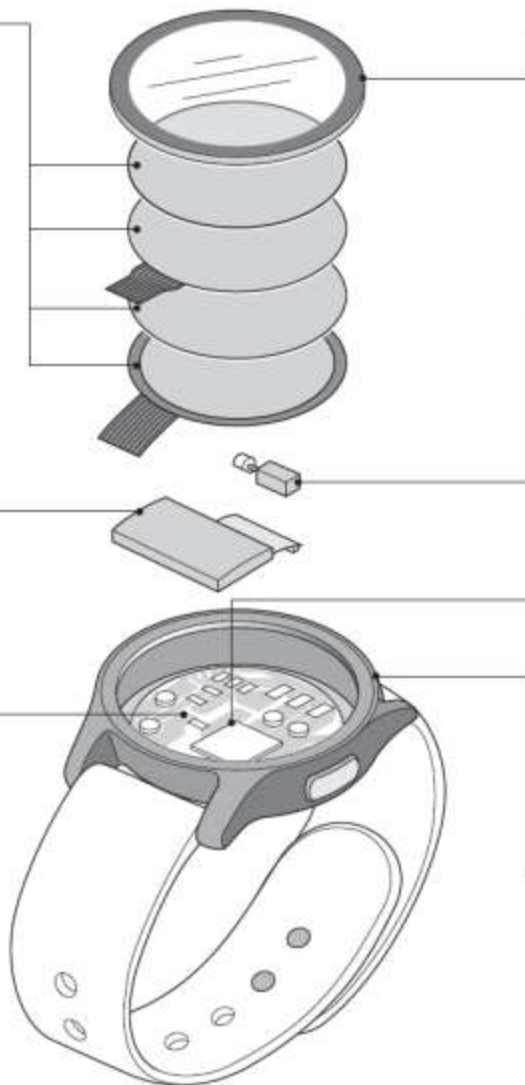

## Camera Module

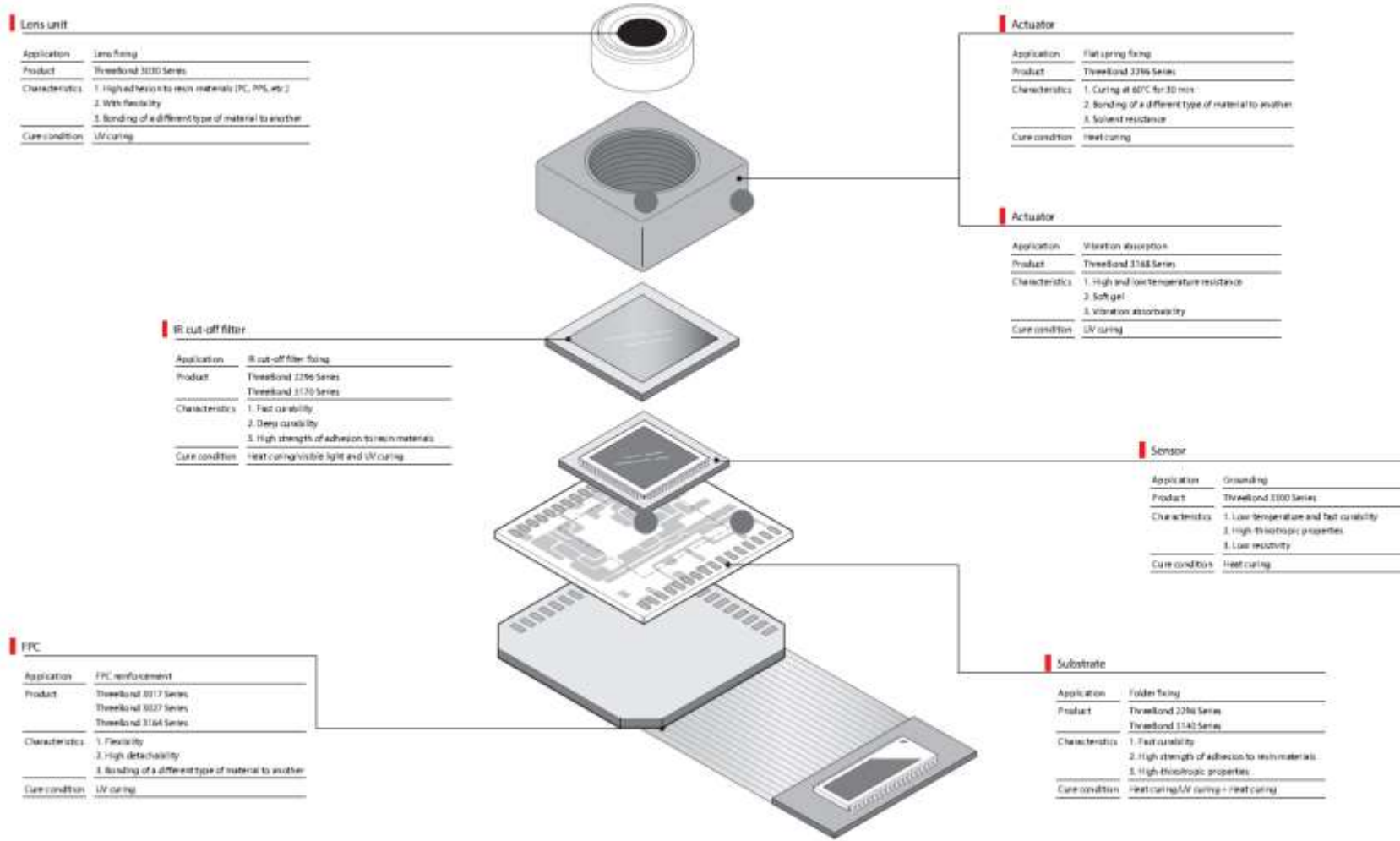

## Camera



|                        |   |
|------------------------|---|
| <b>Application</b>     | Pentaprism fixing   |
| <b>Product</b>         | ThreeBond 3030 Series   |
| <b>Characteristics</b> | 1. High adhesion to resin materials (PC, PPS, etc.)<br>2. Flexible<br>3. Bonding of a different type of material to another |
| <b>Cure condition</b>  | UV curing   |

### Glass and resin lens

|                        |  |
|------------------------|--|
| <b>Application</b>     | Bonding of lenses  |
| <b>Product</b>         | ThreeBond 3017 Series<br>ThreeBond 3020B<br>ThreeBond 3074C  |
| <b>Characteristics</b> | 1. High strength of adhesion to materials difficult to bond (olefin-based)<br>2. Good surface wettability<br>3. Less distortion (TB 3017 Series) |
| <b>Cure condition</b>  | UV curing / LED curing   |

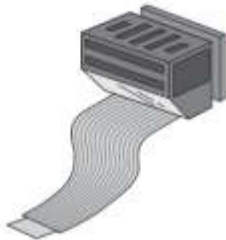

|                        |  |
|------------------------|--|
| <b>Application</b>     | AF sensor fixing   |
| <b>Product</b>         | ThreeBond 1523 Series<br>ThreeBond 3017 Series   |
| <b>Characteristics</b> | 1. Good impact resistance<br>2. Bonding of a different type of material to another<br>3. Shadow-zone curing possible |
| <b>Cure condition</b>  | Moisture curing / UV curing / LED curing   |

### Strobe

|                        |  |
|------------------------|--|
| <b>Application</b>     | Strobe periphery fixing  |
| <b>Product</b>         | ThreeBond 1523 Series<br>ThreeBond 3164D   |
| <b>Characteristics</b> | 1. Good impact resistance<br>2. Bonding of a different type of material to another<br>3. Shadow-zone curing possible |
| <b>Cure condition</b>  | Moisture curing / UV curing  |

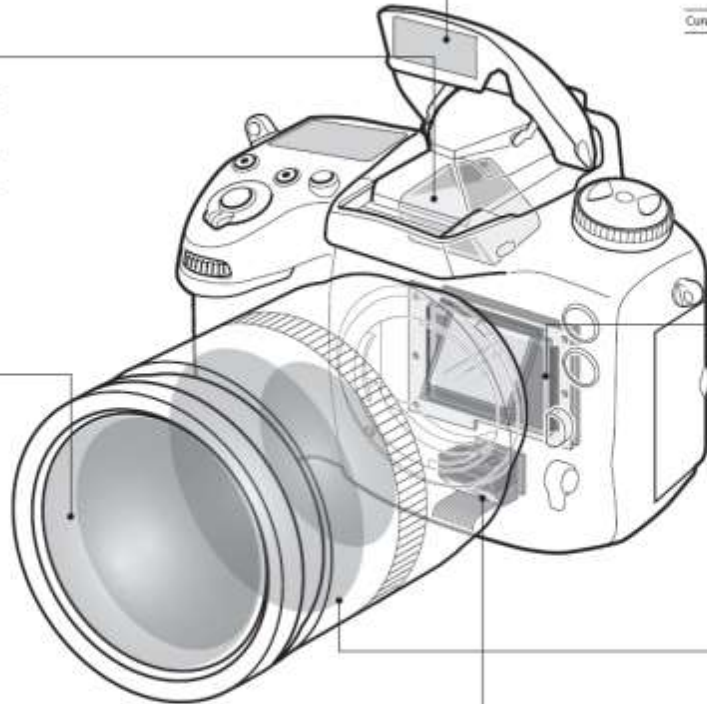

### Image pickup device

|                        |   |
|------------------------|---|
| <b>Application</b>     | Image pickup device fixing  |
| <b>Product</b>         | ThreeBond 3030 Series<br>ThreeBond 3114   |
| <b>Characteristics</b> | 1. Low cure shrinkage<br>2. Low linear expansion coefficient<br>3. High adhesive strength |
| <b>Cure condition</b>  | UV curing   |

|                        |  |
|------------------------|--|
| <b>Application</b>     | Photographing element heat dissipation   |
| <b>Product</b>         | ThreeBond 1225 Series  |
| <b>Characteristics</b> | 1. High thermal conductivity (1.59 to 2.5W/m·K)<br>2. Low molecular weight cyclic siloxane reduced product |
| <b>Cure condition</b>  | Moisture curing  |

### Image stabilizer unit

|                        |   |
|------------------------|---|
| <b>Application</b>     | Vibration absorption  |
| <b>Product</b>         | ThreeBond 3168 Series   |
| <b>Characteristics</b> | 1. High and low temperature resistance<br>2. Soft gel<br>3. Vibration absorbability |
| <b>Cure condition</b>  | UV curing   |

## Surveillance Camera

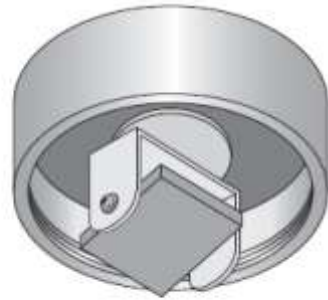

### Image pickup device

|                 |  |
|-----------------|--|
| Application     | Photographing element heat dissipation   |
| Product         | ThreeBond 1225 Series  |
| Characteristics | 1. High thermal conductivity (1.59 to 2.5W/m·K)<br>2. Low molecular weight cyclic siloxane reduced product |
| Cure condition  | Moisture curing  |

### Lens unit

|                 |   |
|-----------------|---|
| Application     | Lens fixing   |
| Product         | ThreeBond 3020B<br>ThreeBond 3030 Series<br>ThreeBond 3074C   |
| Characteristics | 1. High adhesion to resin materials (PC, PPS, etc.)<br>2. Flexible<br>3. Bonding of a different type of material to another |
| Cure condition  | UV curing / LED curing  |

### IR cut-off filter

|                 |   |
|-----------------|---|
| Application     | IR cut-off filter fixing  |
| Product         | ThreeBond 3170 Series   |
| Characteristics | 1. Fast curability<br>2. Deep curability<br>3. High strength of adhesion to resin materials |
| Cure condition  | Visible light and UV curing   |

### Sensor

|                 |   |
|-----------------|---|
| Application     | Image pickup device fixing  |
| Product         | ThreeBond 3036 Series<br>ThreeBond 3114   |
| Characteristics | 1. Low cure shrinkage<br>2. Low linear expansion coefficient<br>3. High adhesive strength |
| Cure condition  | UV curing   |
| Application     | Grounding   |
| Product         | ThreeBond 3331D   |
| Characteristics | 1. Curing at 80°C for 60 min<br>2. Low resistivity<br>3. High adhesion to metal parts     |
| Cure condition  | Heat curing   |

### Top cover

|                 |  |
|-----------------|--|
| Application     | Water repellent coating  |
| Product         | ThreeBond 2907   |
| Characteristics | 1. Single-component (silane-based)<br>2. Antifouling<br>3. Weather resistant |
| Cure condition  | Moisture curing  |

### Case

|                 |  |
|-----------------|--|
| Application     | Waterproof / insect repellent coating                                      |
| Product         | ThreeBond 3081 Series<br>ThreeBond 3166                                    |
| Characteristics | 1. Low compression permanent distortion<br>2. Flexibility<br>3. Reworkable |
| Cure condition  | UV curing  |

## HDD

### Spindle motor magnet

|                 |   |
|-----------------|---|
| Application     | Bonding of magnets  |
| Product         | ThreeBond 2202P   |
| Characteristics | 1. High reliability (high Tg and low elasticity)<br>2. Low outgassing |
| Cure condition  | Heat curing   |

### Spindle motor shaft

|                 |   |
|-----------------|---|
| Application     | Shaft fixing                            |
| Product         | ThreeBond 1354 Series                   |
| Characteristics | 1. Fast curability<br>2. Low outgassing |
| Cure condition  | Anaerobic curing with UV curing added   |

### Spindle motor connector

|                 |   |
|-----------------|---|
| Application     | Connector sealing   |
| Product         | ThreeBond 3140 Series   |
| Characteristics | 1. Temporary UV fixing possible (measures against flowability)<br>2. Low outgassing |
| Cure condition  | Heat curing with UV curing added  |

### Spindle motor bearings

|                 |   |
|-----------------|---|
| Application     | Grounding                                       |
| Product         | ThreeBond 3351 C                                |
| Characteristics | 1. Good adhesive strength<br>2. Low resistivity |
| Cure condition  | Heat curing                                     |

### VCM

|                 |  |
|-----------------|--|
| Application     | Bonding of VCM magnets   |
| Product         | ThreeBond 2200 Series  |
| Characteristics | 1. High detachability<br>2. Impact resistance<br>3. Low outgassing |
| Cure condition  | Heat curing  |

### Actuator periphery wire

|                 |  |
|-----------------|--|
| Application     | Wire fixing                              |
| Product         | ThreeBond 3059D                          |
| Characteristics | 1. Low outgassing<br>2. High-thixotropic |
| Cure condition  | UV curing                                |

### Actuator periphery pivot

|                 |   |
|-----------------|---|
| Application     | Pivot fixing                            |
| Product         | ThreeBond 1300 Series                   |
| Characteristics | 1. Fast curability<br>2. Low outgassing |
| Cure condition  | Anaerobic curing with UV curing added   |

### HDD cover

|                 |                                |
|-----------------|--------------------------------|
| Application     | HDD cover sealing              |
| Product         | ThreeBond 1089 Series          |
| Characteristics | 1. Low outgassing<br>2. UV-CPG |
| Cure condition  | UV curing                      |

### Underfill agent for an actuator periphery

|                 |   |
|-----------------|---|
| Application     | Chip fixing   |
| Product         | ThreeBond 2200 Series                                       |
| Characteristics | 1. Low-temperature and fast curability<br>2. Low outgassing |
| Cure condition  | Heat curing   |

### Actuator periphery carriage

|                 |   |
|-----------------|---|
| Application     | Bonding of a carriage and a coil                        |
| Product         | ThreeBond 2200 Series                                   |
| Characteristics | 1. Low-temperature fast curability<br>2. Low outgassing |
| Cure condition  | Heat curing   |

## SSD

### BGA and CSP

|                 |   |
|-----------------|---|
| Application     | BGA and CSP reinforcement   |
| Product         | ThreeBond 2274 Series   |
| Characteristics | 1. Good spreadability and permeability<br>2. High reliability (high Tg and low elasticity)<br>3. High adhesive strength |
| Cure condition  | Heat curing   |

### Chip

|                 |   |
|-----------------|---|
| Application     | Chip heat radiation   |
| Product         | ThreeBond 2955 Series   |
| Characteristics | 1. High heat radiation (4.8 to 5.3W/m <sup>2</sup> )<br>2. Low outgassing<br>3. No low-molecular cyclic siloxane is contained |
| Cure condition  | Moisture curing   |

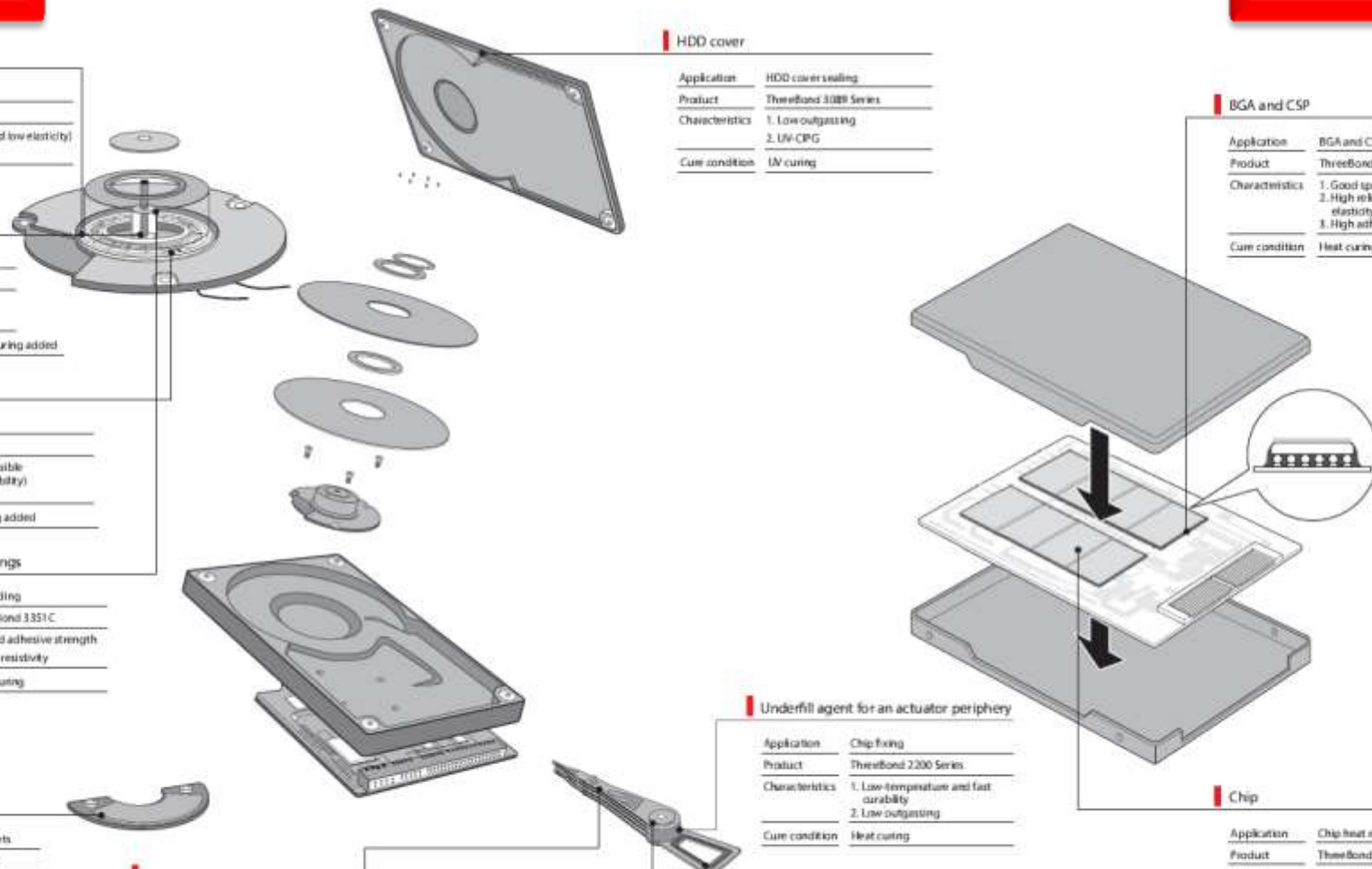

## Optical Pick-up Unit (OPU)

### Coil

|                 |   |
|-----------------|---|
| Application     | Coil fixing   |
| Product         | ThreeBond 2205 Series   |
| Characteristics | 1. Curable at 80°C<br>2. High strength of adhesion to metals and resins<br>3. High reliability (high T <sub>g</sub> and low elasticity) |
| Cure condition  | Heat curing   |

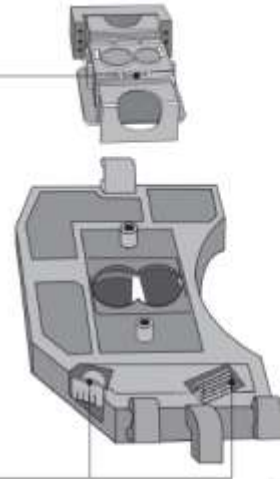

### Actuator

|                 |  |
|-----------------|--|
| Application     | Vibration absorption   |
| Product         | ThreeBond 3160 Series  |
| Characteristics | 1. High and low temperature resistance<br>2. Soft gel<br>3. Vibration absorptability |
| Cure condition  | UV curing  |

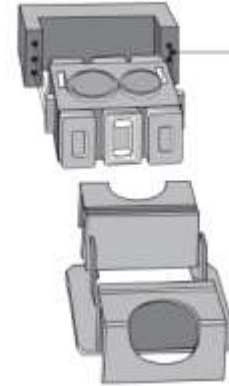

### PD and LD periphery

|                 |   |
|-----------------|---|
| Application     | PD and LD periphery heat radiation  |
| Product         | ThreeBond 2955 Series   |
| Characteristics | 1. High heat radiation (4.8 to 5.7W/m <sup>2</sup> )<br>2. Low outgassing<br>3. No low-molecular cyclic alkane is contained |
| Cure condition  | Moisture curing   |

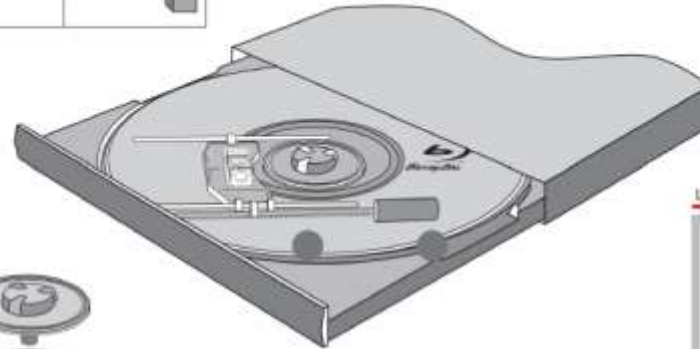

### Motor magnet

|                 |   |
|-----------------|---|
| Application     | Magnet fixing   |
| Product         | ThreeBond 1359 Series                                   |
| Characteristics | 1. Flexibility<br>2. High strength<br>3. Low outgassing |
| Cure condition  | Anaerobic curing  |



### Optical component

|                 |  |
|-----------------|--|
| Application     | Optical component fixing   |
| Product         | ThreeBond 3077 Series  |
| Characteristics | 1. Surface curability<br>2. Low distortion<br>3. High strength of adhesion to resins and glass |
| Cure condition  | UV curing/LED curing   |

### PD and LD

|                 |   |
|-----------------|---|
| Application     | Precision instrument fixing   |
| Product         | ThreeBond 3036 Series<br>ThreeBond 3038 Series<br>ThreeBond 3114 Series   |
| Characteristics | 1. Low cure shrinkage<br>2. Low linear expansion coefficient<br>3. High strength of adhesion to metals and resins |
| Cure condition  | UV curing/LED curing  |

### Lenses

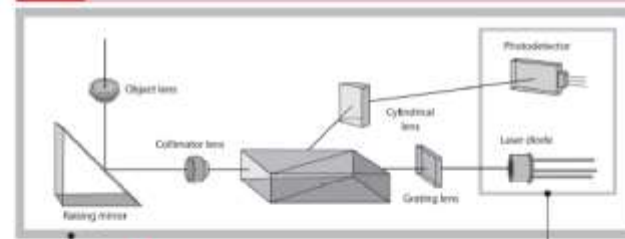



## Ink Jet Printer

## Laser Printer

**Scanner lens**

|                 |  |
|-----------------|--|
| Application     | Scanner lens fixing  |
| Product         | ThreeBond 3017 Series  |
| Characteristics | 1. High strength of adhesion to materials difficult to bond (olefin-based)<br>2. Surface curability<br>3. Bonding of a different type of material to another |
| Cure condition  | UV curing  |

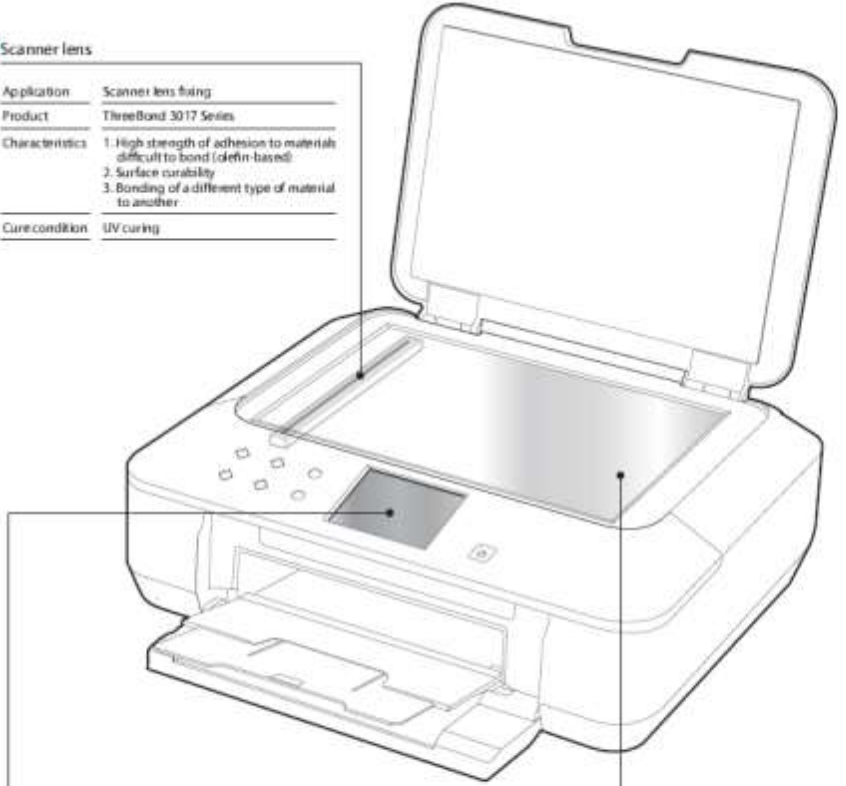

**Touch panel module**

|                 |   |
|-----------------|---|
| Application     | Connection of touch panel terminals   |
| Product         | ThreeBond 3371 (L/S 100/100)<br>ThreeBond 3373 Series (L/S 200/200)   |
| Characteristics | 1. Suitability for screen printing<br>2. Movable after printing and drying<br>3. Compression bonding at low temperature (120°C x 3MPa x 10 sec) |
| Cure condition  | Drying by heating (film formation) and thermocompression bonding  |

**Laminated head**

|                 |  |
|-----------------|--|
| Application     | Head formation   |
| Product         | ThreeBond 2075 Series  |
| Characteristics | 1. Ink resistance<br>2. Fast curability<br>3. High detachability |
| Cure condition  | Heat curing  |

**General-purpose loosening prevention**

|                 |  |
|-----------------|--|
| Application     | Prevention of screws from loosening                              |
| Product         | ThreeBond 2365 Series (screw processing product)                 |
| Characteristics | 1. Prevention of looseness and dropping<br>2. Good repeatability |

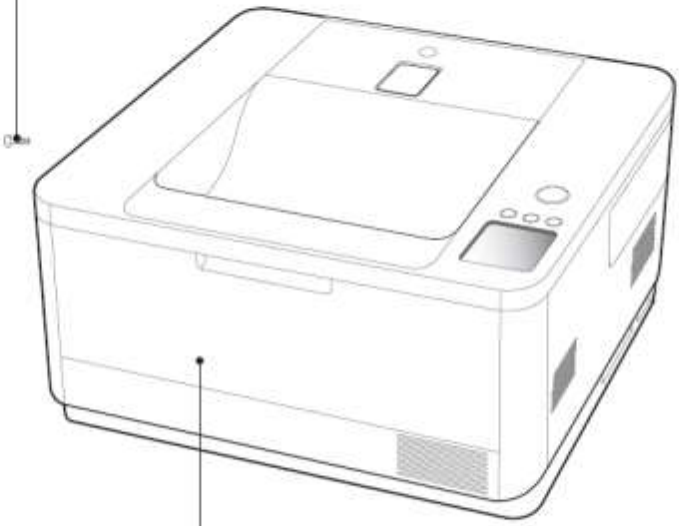

**Lenses**

|                 |  |
|-----------------|--|
| Application     | Lens fixing  |
| Product         | ThreeBond 3017 Series<br>ThreeBond 3038 Series<br>ThreeBond 3114 Series  |
| Characteristics | 1. High strength of adhesion to materials difficult to bond (olefin-based)<br>2. Surface curability<br>3. Bonding of a different type of material to another |
| Cure condition  | UV curing/LED curing   |

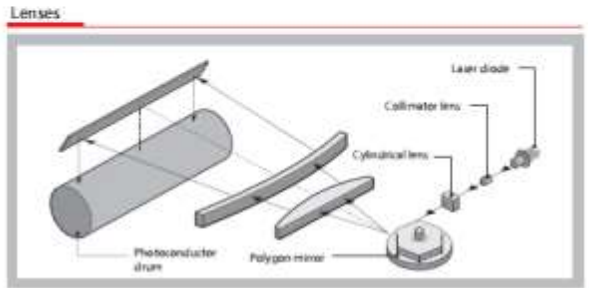

## RFID Standard

## Felicia Standard

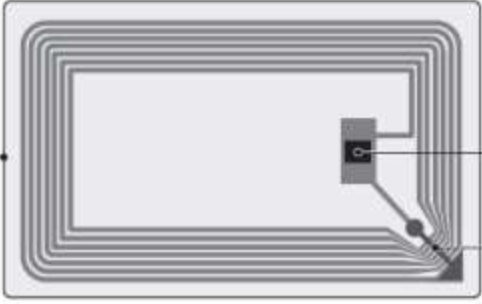

| Circuit         |  | Insulation      |  |
|-----------------|--|-----------------|--|
| Application     | Conductive copper ink for circuit formation                                    | Application     | Insulation coating adhesive                            |
| Developed       | 33A-911  | Product         | ThreeBond 3075 series                                  |
| Product         | (1/5 200/200)  | Characteristics | 1. Fast curing<br>2. Deep part curing<br>3. Insulation |
| Characteristics | 1. High density<br>2. Flexibility (Bend performance)<br>3. Low resistance rate | Cure condition  | UV curing  |
| Cure condition  | Heat curing  |                 |  |

| NFC Tag         |   |
|-----------------|---|
| Application     | Connection of NFC Tag   |
| Product         | ThreeBond 3372 series   |
| Characteristics | 1. Fast curing<br>2. High reliability<br>(Low resistance rate)<br>3. Narrow gap (50 µm) |
| Cure condition  | Heat curing   |

| Circuit         |  | Insulation      |  |
|-----------------|--|-----------------|--|
| Application     | Conductive copper ink for circuit formation                                    | Application     | Insulation coating adhesive                            |
| Developed       | 33A-933-2  | Product         | ThreeBond 3075 series                                  |
| Product         | (1/5 150/150)  | Characteristics | 1. Fast curing<br>2. Deep part curing<br>3. Insulation |
| Characteristics | 1. High density<br>2. Flexibility (Bend performance)<br>3. Low resistance rate | Cure condition  | UV curing  |
| Cure condition  | Heat curing  |                 |  |

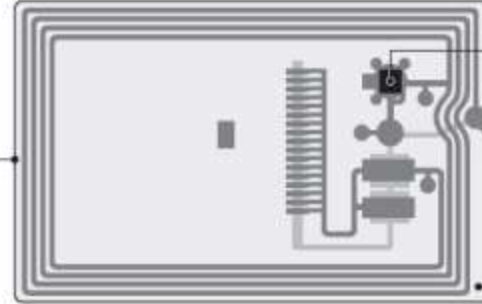
| NFC Tag         |   |
|-----------------|---|
| Application     | Connection of NFC Tag   |
| Product         | ThreeBond 3372 series   |
| Characteristics | 1. Fast curing<br>2. High reliability<br>(Low resistance rate)<br>3. Narrow gap (50 µm) |
| Cure condition  | Heat curing   |

## Crystal Silicon Solar Panel

### Aluminum Frame

|                 |  |
|-----------------|--|
| Application     | Seal   |
| Product         | ThreeBond 1226<br>ThreeBond 1533 series  |
| Characteristics | 1. Possible curing at 25°C<br>2. Excellent adhesion for different materials<br>3. Durability |
| Cure condition  | Moisture curing  |

### Solar Panel

|                 |  |
|-----------------|--|
| Application     | Cleaning   |
| Product         | ThreeBond 0658<br>(Strong alkaline electrolyte water pH=12.5)                  |
| Characteristics | 1. Cleaning<br>2. Eradication of bacteria, antibacterial<br>3. Low stimulation |

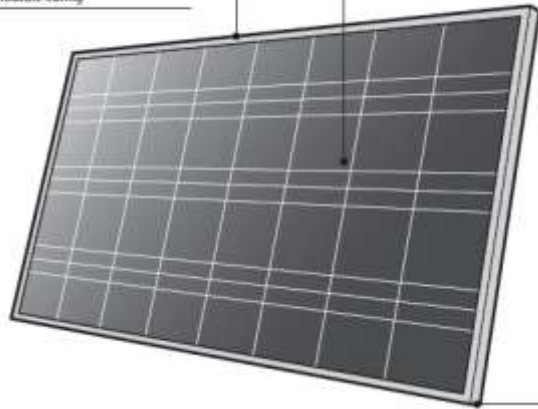

### Crystal Silicon Solar Battery (Peripheral material)

#### Junction Box

|                 |   |
|-----------------|---|
| ① Application   | Diode heat release  |
| Product         | ThreeBond 1225B   |
| Characteristics | 1. Heat dissipation (1.5PW/m-K)<br>2. Low molecular circularity siloxane lowering product |
| Cure condition  | Moisture curing   |

|                 |   |
|-----------------|---|
| ② Application   | Seal  |
| Product         | ThreeBond 1537 Series   |
| Characteristics | 1. UL94V-0 Approved<br>2. Good Adhesion to variety of materials<br>3. Cures at room temperature |
| Cure condition  | Moisture curing   |

#### Installation-related

|                 |   |
|-----------------|---|
| ① Application   | Fixing bolt   |
| Product         | ThreeBond 1305 series<br>ThreeBond 2448 series                  |
| Characteristics | 1. Durability<br>2. High strength<br>3. Possible curing at 25°C |
| Cure condition  | Anaerobic curing / Room temperature curing                      |

|                 |   |
|-----------------|---|
| ② Application   | Seal  |
| Product         | ThreeBond S200 series   |
| Characteristics | 1. Excellent adhesion for different materials<br>2. Possible curing at 25°C |
| Cure condition  | Moisture curing   |

## Organic Thin Film Solar Panel

### Organic Thin Film Solar Battery Whole Surface Solid Sealing

|                 |   |
|-----------------|---|
| Application     | Whole Surface Solid Sealing                                     |
| Product         | ThreeBond 1655  |
| Characteristics | 1. High transparent<br>2. Flexibility<br>3. Even film thickness |
| Cure condition  | Heat curing   |

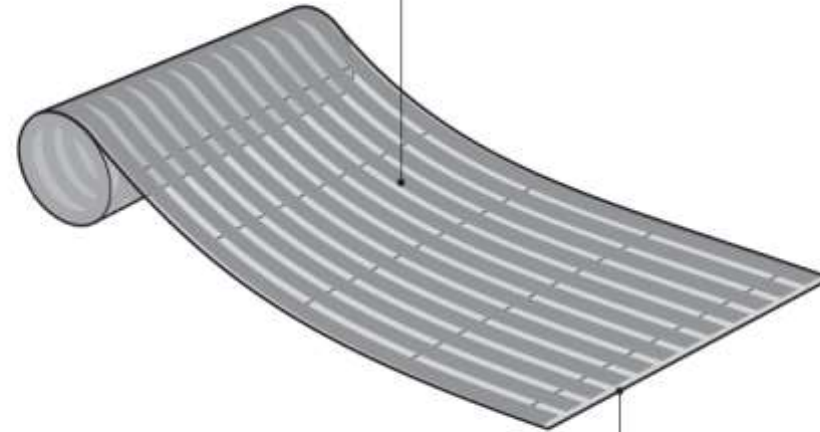

### Organic Thin Film Solar Battery For Sealing

|                 |   |
|-----------------|---|
| Application     | Sealing   |
| Product         | ThreeBond 3118 series                               |
| Characteristics | 1. Low moisture permeability<br>2. High reliability |
| Cure condition  | UV curing + Heat curing                             |

## Medical

### Swabs / Examination Kits



Attaching spindles to sponges

### Winged Infusion Needles



Bonding needles to their bases

### Indwelling and Blood Collection Needles

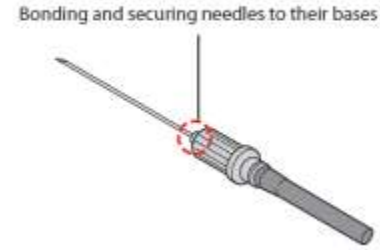

Bonding and securing needles to their bases

### Stopcocks and Blood Filters

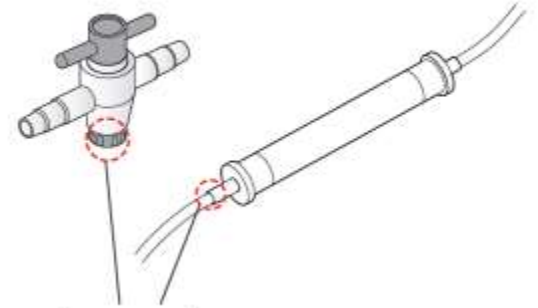

Securing connectors

### Medical Tubes



Bonding connectors to tubes

### Inlet Pipes

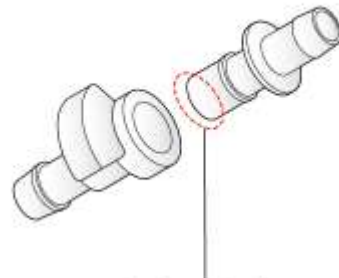

Couple part bonding

### Injection Needles

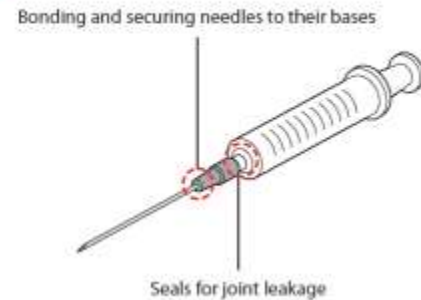

Bonding and securing needles to their bases

Seals for joint leakage

### Drip Tubes

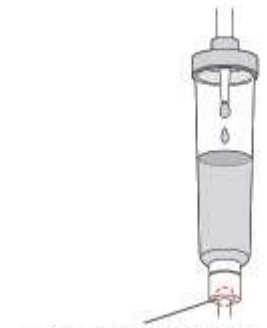

Bonding connectors to tubes

## Medical

### Thermometers

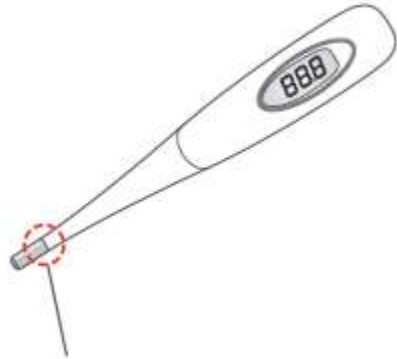

Securing measurement part caps

### Connector Parts

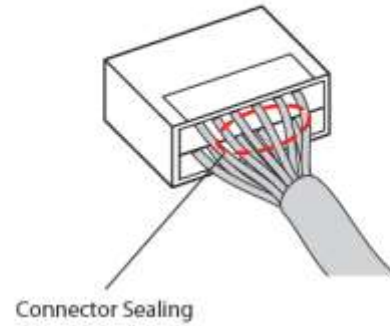

Connector Sealing

### Measurement Equipment



Case seals

### Thermistor Sensors

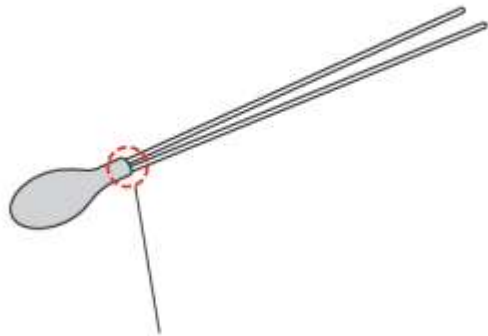

Precise securing of tip parts

### Endoscopes



Securing lenses and tip parts

### Wearable Equipment



Case sealing



# Thank you for your attention !

Contributing to world manufacturing  
with a high-quality and  
reliable production system

Developing a high-quality and reliable production  
system to meet the needs of our customers

